

**DESIGN LOADS:**

All loads are unfactored.

- Roof Loads:** Live Loads = 1.36 kPa (Ss = 1.2 kPa, Sr = 0.4 kPa)  
Water Storage = 1.47 kPa  
Dead Loads = 10.1 kPa Brackets, Slab, Beam, Collateral and Mechanical.
- Floor Loads:** Live Loads = 1.9 kPa (Private) 4.8 kPa (Public)  
Dead Loads = 8.6 kPa
- Parking Deck Loads:** Live Loads = 12 kPa  
Dead Loads = 20 kPa
- Earthquake Loads:** Sa(0.2) = 0.190  
Sa(0.5) = 0.120  
Sa(1.0) = 0.072  
Sa(2.0) = 0.023  
PGA = 0.074
- Wind Loads:**  $\frac{1}{30} = 0.48$  kPa
- Seismic Soil Classification: C

**GENERAL:**

- All materials and workmanship shall be in conformance with the Ontario Building Code.
- Where standards published by various organizations are referred, conform to latest edition of standards as amended and revised to date of contract.
- All dimensions, elevations, openings for pipes, sleeves, equipment locations and the like shall be checked with the architectural and the appropriate structural, mechanical or electrical drawings. Report any discrepancies before proceeding with the work.
- Do not scale the drawings.
- The Contractor shall examine the site and satisfy himself of the actual conditions and requirements of the work.
- Check underground utilities and assume responsibility for same during construction.
- Set all anchors, inserts, etc. as required by other trades.
- The Contractor shall caulk and seal all joints, spaces, etc. to provide a weather-tight building.
- The Contractor shall make any necessary allowances for any variations and/or any revisions made on account of sub-trades and product selection for the completion of the project.
- Features of construction not fully shown shall be of the same character as shown for similar conditions.
- Confirm all measurements that govern the scope of work built into existing building.

**EXCAVATION, GRADING & BACKFILLING:**

- Refer to soil test report, if there is any, for the borehole data and site conditions.
- The accuracy of the soil test report is not guaranteed. Soil data applies for actual test pit location and conditions may differ at other parts of the site.
- All spread footings shall be placed on undisturbed native material. Have base inspected by Engineer before placing footing.
- Design bearing pressure to be 200 kPa (SLS) as per cambiums geotechnical report.
- Excavate and remove all fills, surface features and topsoil from building area before starting the work.
- Protect foundations, slabs on grade, footings, and adjacent soil against freezing and frost action at all times during construction.
- Backfill footings using approved free draining materials.
- Place backfill simultaneously on both sides of walls below grade.
- Slab on grade shall be placed on soil capable of safely sustaining 30 kPa without settlement related to building footings.
- Slab on grade shall be, unless otherwise stated, 100mm thick poured concrete reinforced with 152x152 MW18.7/MW18.7 WWF, on 150mm deep crushed stones compacted to at least 96% standard proctor maximum dry density.
- Restore exterior surfaces to condition equal to that existing prior to excavation unless otherwise noted.

**CONCRETE & REINFORCING STEEL:**

- Concrete construction shall conform to CAN/C.S.A. A23.1-14.
- Concrete compressive strength to be 30MPa at 28 days, maximum aggregate size to be 20mm, slump to be 75mm maximum, unless otherwise stated.
- Concrete cover for reinforcements shall be in accordance with Ontario Building Code and C.S.A. A23.1-14.
- Exposed concrete shall have air entrainment of 6-7%.
- Form all vertical surfaces of concrete work, where neat excavation in native soil are possible. Concrete for footings need not be formed.
- All floor surfaces shall be level to a tolerance of 10mm and not out of plane by more than 3mm on 3000mm template. Steel trowel finish all floors.
- Reinforcing steel shall be in accordance with C.S.A. G30.18-M92, Grade 400.
- Welded wire fabric shall be in accordance with C.S.A. G30.15-M83.
- The Contractor shall prepare and submit six (6) copies of shop drawings indicating material, size, spacing, and location of reinforcing steel, anchors, and details.
- Reinforcing bars shall be continuous across construction joints and elevation variations unless noted. Continuous bars shall be fully developed by lapping where spliced.

**MASONRY:**

- Masonry work shall be in accordance with C.S.A. standards A371-14 and the Ontario Building Code.
- Modular concrete block masonry units conform to C.S.A. A165.1-14, A165.2-14 and A165.3-14. Solid block and semi-solid block shall be used in locations shown on drawings.
- Masonry mortar for load bearing walls shall be type S conforming to C.S.A. A179-14.
- Install continuous bond beam where open web steel joist bear on masonry walls unless otherwise notes.
- Over openings or recesses in masonry walls including those for mechanical or electrical services and equipments, provide lintels as per lintel schedule. Where no lintel schedule is provided supply masonry lintels reinforced with 1-10m reinforcing bars at bottom. Provide minimum 100mm bearing at each end.
- Provide cavity wall reinforcement in all masonry walls. For block and brick walls - Tri-Loc BL11 (Blok-Lok). For plain masonry - heavy duty ladder type masonry reinforcement to suit block size.
- Concrete fill for masonry units to have a minimum compressive strength of 25 MPa at 28 days unless otherwise noted.
- Where bricks are indicated, supply metric modular bricks of type shown unless otherwise noted. Compressive strength of bricks to exceed 40 MPa. Provide solid masonry units below all beams and lintel bearings.
- Where anchors are cast into masonry, fill voids with concrete to two (2) courses below bearing and a minimum of 200mm each side of bearing.
- Provide solid reinforcing core with 1 - 15M continuous adjacent to all wall and door openings and building corners.

**PRECAST CONCRETE SLAB:**

- Pre-cast pre-stressed hollow core slabs shall be designed in accordance with C.S.A. A23.1-14 under the supervision of a Professional Engineer in the Province of Ontario.
- Shop drawings showing the hollow core slab layout, and details of prestressing and reinforcement shall be submitted to the Consultant for review prior to manufacturing.
- Concrete shall have a minimum compressive strength of 31 MPa. at transfer and 41 MPa. at 28 days.
- The pre-stress strand shall be uncoated 7-wire cable conforming to C.S.A.-CAN3-A23.4-M78 and ASTM A416, A421.
- Provide approved grout having minimum compressive strength of 35 MPa. at 28 days for shear keys in slab joints.
- Provide 10m dowels to masonry at each joint between slabs at end bearing and at 2400mm on centre at junction between edge of slabs and end wall. Grout or concrete fill side ties to wall.

**STEEL - INSPECTION AND TESTING:**

- The undertaking to inspect welding shall be qualified in accordance with the requirements of CSA W178.1, "Certification of Welding Inspection Organizations", and certified by the Canadian Welding Bureau.
- The inspection shall cover all moment connections to review for compliance with the CSA S16.
- The inspection agency shall submit reports to the consultant covering the Work inspected and provide details of nonconformities or deficiencies observed.

**STRUCTURAL STEEL:**

- Rolled shapes and plates shall conform to CAN/C.S.A. G40.20-13/G40.21-13 (R.2018), Grade 350W.
- Hollow structural sections shall conform to CAN/C.S.A. G40.20-13/G40.21-13 (R.2018), Grade 350W.
- Pipe column sections shall conform to ASTM A53, 240 MPa.
- Bolts to be A325 high strength steel bolts for friction type connections, and A307 for anchor bolts.
- Steel deck finish to be zinc coated to A.S.T.M. A123M-17
- Fabrication, erection and workmanship shall be performed by a welder qualified under C.S.A. W47.
- Surfaces to be welded shall be thoroughly cleaned of all foreign matter including paint film.
- All welded joints shall use E49XX electrodes. Connections that are friction type shall use 20mm diameter ASTM A325-14 high strength bolts unless otherwise noted.
- All steel deck shall be in conformance with C.S.A. S-136-17 and shall be designed to safely support all the loads indicated on the drawings.
- Steel decks to be designed to act as diaphragms. Decks to have wipe coat galvanized finish unless noted otherwise on drawings.
- Steel decks and joists shall have a maximum deflection under live load of 1/240 of span.
- Shop prime all structural steel with primer. Do not paint contact surfaces of joints or surfaces to receive field welds.
- The Contractor shall prepare and submit to the Consultant for review six (6) copies of erection diagrams and shop drawings indicating material, size, spacing and location of structural steel members, connection, bridging, reinforcing, bearing shoes, anchors, elevations and details.
- The Contractor shall prepare and submit to the Consultant six (6) catalogues or tables of joists and steel deck checked and approved by a Professional Engineer of Ontario.
- All loads specified are unfactored in accordance with C.S.A. S16.

**COLD FORMED STEEL:**

- Unless otherwise specified, Cold Formed Steel to conform to CSA-S16, Steel Structures for Building - Limit States Design and CAN/CSA-S136, Cold Formed Steel Structural Members.
- Work to be executed by firm thoroughly conversant with laws, by-laws and regulations which govern, and capable of workmanship of best grade of modern shop and field practice known to recognized manufacturer's specializing in this work.
- Work shall be executed by workers especially trained and experienced in this type of work. Have a full time, senior, qualified representative at the site to direct the work.
- Install system to provide for movement of components without damage, failure of joint seals, undue stress on fasteners, or other detrimental effects when subject to seasonal or cyclic day/night temperature ranges.
- Install system to accommodate construction tolerances, deflection of building structural members, and clearances of intended openings.
- Galvanized Sheet Steel shall conform to ASTM A653/A653M, minimum Grade D, 50 PSI (345 MPa) yield for 1.5mm (.060") material.
- Structural Metal Studs to be galvanized sheet steel formed to channel shape, of minimum gauge, sizes, and section properties to meet design requirements, and conforms to ASTM C955.
- Metal Stud Runners/Top and Bottom Tracks to be Galvanized sheet steel formed to channel shape, having same width as studs, with tight fit and solid web, of minimum gauge to meet design requirements, but no less than gauge of metal studs, and conforms to ASTM C955.
- Metal Plates, Bridging, Gussets and Clips to be Formed from galvanized sheet steel, of gauges, shapes and sizes required to meet design requirements determined for conditions encountered, and of some finish as framing members.
- Fasteners to be Self-drilling, Self-tapping Screws, Bolts, Nuts and Washers: Hot-dip galvanized to 1.25 ounce per square foot and conforms to ASTM A153/A153M-09, Class B3, '12-24 x 7/8 HWH #4STLG' by Hilti Canada, or approved equal.
- Anchorage Devices to be power driven, powder actuated, drilled expansion bolts, or screws with sleeves, as application dictates.
- Where required welding shall be performed by a welder qualified under C.S.A. W47.
- Welding Materials to conform to CSA W59.
- Electrodes for welding shall have minimum 480 Mpa tensile strength series, (E480XX, E480S-X).
- Provide Bridging for restraining member rotation and translation. Bridging shall be continuous and spaced at 1200mm O/C vertical maximum.
- The Contractor shall prepare and submit to the Consultant for review six (6) copies of erection diagrams and shop drawings indicating material, size, spacing and location of structural cold form steel members, connection, bridging, reinforcing, bearing, anchors, elevations and details.

**LEGEND:**

- F = FOOTING  
SF = STRIP FOOTING  
P = PIER  
FW = FOUNDATION WALL  
BL = BASE PLATE  
C = COLUMN  
SW = STRUCTURAL WALL  
LWD = WOOD LINTEL  
LCF = COLD FORM STEEL LINTEL  
LST = STEEL LINTEL  
LCO = CONCRETE LINTEL  
LBB = BOND BEAM LINTEL  
F = FLOOR  
R = ROOF  
BOT = BOTTOM  
EXT = EXTERIOR  
INT = INTERIOR  
E/W = EACH WAY  
E/F = EACH FACE  
O/C = ON CENTER  
U/S = UNDER SIDE  
T/S = TOP OF STEEL  
TYP = TYPICAL  
WWF = WELDED WIRE MESH  
MW = METAL WIRE  
FFE = FINISHED FLOOR ELEVATION  
W/ = WITH  
TJ = TIE JOIST  
PL = POINT LOAD  
(HIGH) = BEAM AT UPPER LEVEL  
(LOW) = BEAM AT LOWER LEVEL  
CANT. = CANTILEVERED

1	ISSUED FOR PERMIT	20/03/30	M.S.	T.L.R.
NO.	REVISION	DATE	BY	APPROVED
REVISIONS				
513 DUNDAS STREET EAST, WHITBY, ON KIYA DEVELOPMENTS LTD.				
<b>STRUCTURAL NOTES &amp; LEGEND</b>				
 <b>D.G. Biddle &amp; Associates Limited</b> consulting engineers and planners 96 KING STREET EAST • OSHAWA, ON L1H 1B6 PHONE (905)576-8500 • FAX (905)576-9730 info@dgibiddle.com				
SCALE: AS SHOWN		PROJECT NO. 116194		
DRAWN BY: M.A.S.		DRAWING NO. S1		
DESIGN BY: T.L.R.		CAD FILE: -		
CHECKED BY: D.D.B.		PLOT DATE: 20/06/22		
DATE: JANUARY 2020		SUBMISSION: PERMIT		

FOUNDATION PAD SCHEDULE		
FOOTING	SIZE	REINFORCING
F1	4800x4800x1000	W/ 48-15M REINF. O/C E/W
F2	4000x4000x775	W/ 35-15M REINF. O/C E/W
F3	1650x1650x350	W/ 17-15M REINF. O/C E/W
F4	2750x2750x600	W/ 17-15M REINF. O/C E/W
F5	3800x3800x750	W/ 32-15M REINF. O/C E/W
F6	3400x3400x650	W/ 26-15M REINF. O/C E/W
F7	1350x1350x275	W/ 4-15M REINF. O/C E/W

PIER SCHEDULE				
PIER	SIZE	VERT. REINF.	HORIZ. REINF.	REMARKS
P1	400x600			
P2	400x300			

FOUNDATION WALL & STRIP FOOTING SCHEDULE		
WALL	SIZE	STRIP FOOTING SIZE
FW1	300 CONCRETE FOUNDATION WALL W/20M VERT. REINF. @270 O/C W/15M HORIZ. REINF. @400 O/C INSIDE FACE W/10M REINF. @400 O/C E/W OUTSIDE FACE	600x200 CONCRETE STRIP FOOTING W/2-15M CONT. REINF. W/15M HOOKED DOWELS TO MATCH VERT. WALL REINF. ALTERNATE LEGS 900 L 600
FW2	300 CONCRETE FOUNDATION WALL W/15M VERT. REINF. @250 O/C W/15M HORIZ. REINF. @400 O/C INSIDE FACE W/10M REINF. @400 O/C E/W OUTSIDE FACE	600x200 CONCRETE STRIP FOOTING W/2-15M CONT. REINF. W/15M HOOKED DOWELS TO MATCH VERT. WALL REINF. ALTERNATE LEGS 900 L 600
FW3	300 CONCRETE FOUNDATION WALL W/15M VERTICAL REINF. @210 O/C E/W W/15M HORIZ. REINF. @400 O/C E/W E/F	2100x300 CONCRETE STRIP FOOTING W/15M CONT. REINF. @400 O/C E/F W/15M TRANSVERSE REINF. @150 O/C E/F W/15M HOOKED DOWELS TO MATCH VERT. WALL REINF. 900 L 600
FW4	200 CONCRETE FOUNDATION WALL W/15M @400 O/C E/W	600x200 CONCRETE STRIP FOOTING W/2-15M CONT. REINF. W/15M HOOKED DOWELS TO MATCH VERT. WALL REINF. ALTERNATE LEGS 900 L 600
FW5	250 CONCRETE FOUNDATION WALL W/15M VERT. REINF. @300 O/C W/15M HORIZ. REINF. @400 O/C	600x200 CONCRETE STRIP FOOTING W/2-15M CONT. REINF. W/15M HOOKED DOWELS TO MATCH VERT. WALL REINF. ALTERNATE LEGS 900 L 600
FW6	350 CONCRETE FOUNDATION WALL W/20M VERT. REINF. @330 O/C W/15M HORIZ. REINF. @400 O/C INSIDE FACE W/10M REINF. @400 O/C E/W OUTSIDE FACE	600x200 CONCRETE STRIP FOOTING W/2-15M CONT. REINF. W/15M HOOKED DOWELS TO MATCH VERT. WALL REINF. ALTERNATE LEGS 900 L 600
FW7	350 CONCRETE FOUNDATION WALL W/15M VERT. REINF. @280 O/C W/15M HORIZ. REINF. @400 O/C INSIDE FACE W/10M REINF. @400 O/C E/W OUTSIDE FACE	600x200 CONCRETE STRIP FOOTING W/2-15M CONT. REINF. W/15M HOOKED DOWELS TO MATCH VERT. WALL REINF. ALTERNATE LEGS 900 L 600
FW8	600 POURED CONCRETE W/8-25M VERT. REINF. @75 O/C W/15M @400 O/C HORIZ.	
FW9	600 POURED CONCRETE W/8-30M VERT. REINF. @100 O/C W/15M @400 O/C HORIZ.	
FW10	400 POURED CONCRETE W/3-20M VERT. REINF. @100 O/C W/15M @400 O/C E/F HORIZ.	
FW11	200 POURED CONCRETE W/25M VERT. REINF. @125 O/C W/15M @400 O/C HORIZ.	

BASE PLATE SCHEDULE		
BASE PLATE	MEMBER	ANCHORS
BP1	300x150x12 STEEL PLATE	2-20M HOOKED ANCHORS 300 L 50
BP2	200x140x12 STEEL PLATE	2-15M HOOKED ANCHORS 300 L 50
BP3	400x300x16 STEEL PLATE	4-20M HOOKED ANCHORS 400 L 50

ROOF SCHEDULE			
R1	38x0.76 STEEL DECK W/ L102x102x6.4 CONT. PERIMETER ANGLE	R2	800S162-33 @400 O/C W/ 800T150-33 CONT. PERIMETER TRACKS W/16 PLYWOOD SHEATHING

CONCRETE MIX SCHEDULE				
STRENGTH	CLASS	AIR	SLUMP	LOCATION
30 MPa	C-1	6-7%	75mm	RAMP & ADJACENT RETAINING WALLS, SUSPENDED PARKING SLAB
30 MPa	N	6-7%	75mm	CORE, COLUMNS, BEAMS, FOUNDATION WALLS, STRIP FOOTINGS
25 MPa	C-4	N/A	75mm	SLAB ON GRADE IN UNDERGROUND PARKING GARAGE

LINTEL SCHEDULE SCHEDULE		
LINTEL	SIZE	REMARKS
LST1	L89x89x6.4 DOUBLE STEEL ANGLE	10M HOOKED DOWEL @ ENDS 300 L 50
LST2	L127x89x6.4 LLV DOUBLE STEEL ANGLE	10M HOOKED DOWEL @ ENDS 300 L 50
LST3		
LST4		
LC01	600x400 W/3-20M CONT. T&B REINF. W/10M STIRRUPS @300 O/C	
LC02	400x400 W/3-15M CONT. T&B REINF. W/10M STIRRUPS @300 O/C	
LC03	800x200 W/3-15M CONT. T&B REINF. W/10M STIRRUPS @300 O/C	
LC04	600x350 W/3-20M CONT. T&B REINF. W/10M STIRRUPS @300 O/C	
LC05	400x200 W/3-15M CONT. T&B REINF. W/10M STIRRUPS @300 O/C	
LC06	400x300 W/3-15M CONT. T&B REINF. W/10M STIRRUPS @300 O/C	

WALL PLATE SCHEDULE		
WALL PLATE	MEMBER	ANCHORS
WP1	300x150x12 STEEL WALL PLATE	HILTI HY-200 ADHESIVE W/4-16 # HIT-Z RODS W/150 EMBED.
WP2	300x200x16 STEEL WALL PLATE	6-20M HOOKED ANCHORS Vf=19kN, Mf=11.5kN*m

STRUCTURAL WALL SCHEDULE		
WALL	SIZE	REMARKS
SW1	190 CMU MASONRY BLOCK W/15M VERT. REINF. @1200 O/C	
SW2	275 CONCRETE WALL CURB W/15M @400 O/C E/W E/F	
SW3	600S162-33 COLD FORM STUDS @400 O/C W/ 600T150-33 TOP AND BOTTOM TRACKS W/16 PLYWOOD SHEATHING	W/2-0.157 X-U KNURLED SHANK FASTENERS @400 O/C W/ 25 EMBED. INTO CONCRETE
SW4	200 POURED CONCRETE W/25M VERT. REINF. @125 O/C W/15M @400 O/C HORIZ.	
SW5	600 POURED CONCRETE W/8-30M VERT. REINF. @100 O/C W/15M @400 O/C HORIZ.	
SW6	600 POURED CONCRETE W/8-25M VERT. REINF. @75 O/C W/15M @400 O/C HORIZ.	
SW7	250 POURED CONCRETE W/3-25M VERT. REINF. @100 O/C FOR 6 ROWS @ ENDS OF SHEARWALL W/2-25M VERT. INTERMEDIATED REINF. @150 O/C W/15M @400 O/C HORIZ.	
SW8	600 POURED CONCRETE W/8-30M VERT. REINF. @100 O/C W/15M @400 O/C HORIZ.	
SW9	400 POURED CONCRETE W/4-25M VERT. REINF. @150 O/C W/15M @400 O/C HORIZ.	
SW10	250 POURED CONCRETE W/3-25M VERT. REINF. @100 O/C @ ENDS OF SHEARWALL W/2-25M VERT. INTERMEDIATED REINF. @300 O/C W/15M @400 O/C HORIZ.	
SW11	400 POURED CONCRETE W/3-20M VERT. REINF. @100 O/C W/15M @400 O/C E/F HORIZ.	
SW12	200 POURED CONCRETE W/25M VERT. REINF. @200 O/C W/15M @400 O/C HORIZ.	
SW13	600 POURED CONCRETE W/8-25M VERT. REINF. @200 O/C W/15M @400 O/C HORIZ.	
SW14	400 POURED CONCRETE W/2-20M VERT. REINF. @150 O/C W/15M @400 O/C HORIZ.	

COLUMN SCHEDULE										
SPAN	COLUMN	C1	C2	C3	C4	C5	C6	C7	C8	C9
ROOF										
3500	DL=	565	340	280	290	180			350	
	LL=	203	120	100	100	60			120	
	Pf=	1020	600	500	520	320			620	
	SIZE=	600x400	600x400	600x400	600x400	600x400			600x400	
6TH FLOOR	V REINF.=	6-25M	6-25M	6-25M	6-25M	6-25M			6-25M	
	DL=	1050	630	520	550	340			650	
	LL=	300	180	140	150	90			180	
	Pf=	1800	1060	880	900	560			1085	
3500	SIZE=	600x400	600x400	600x400	600x400	600x400			600x400	
	V REINF.=	6-25M	6-25M	6-25M	6-25M	6-25M			6-25M	
	DL=	1540	925	760	800	500			950	
	LL=	400	230	190	200	110			240	
5TH FLOOR	Pf=	2550	1520	1250	1300	800			1550	
	SIZE=	600x400	600x400	600x400	600x400	600x400			600x400	
	V REINF.=	6-25M	6-25M	6-25M	6-25M	6-25M			6-25M	
	DL=	2025	1220	1000	1050	660			1250	
3500	LL=	500	300	230	250	140			300	
	Pf=	3300	1975	1620	1700	1050			2020	
	SIZE=	600x400	600x400	600x400	600x400	600x400			600x400	
	V REINF.=	8-25M	6-25M	6-25M	6-25M	6-25M			6-25M	
3RD FLOOR	DL=	2500	1510	1250	1300	810			1550	
	LL=	600	350	275	290	170			360	
	Pf=	4080	2450	2000	2080	1300			2490	
	SIZE=	800x400	600x400	600x400	600x400	600x400			600x400	
2ND FLOOR	V REINF.=	8-25M	6-25M	6-25M	6-25M	6-25M			6-25M	
	DL=	3000	1800	1500	1550	975			1850	
	LL=	700	400	320	340	190			410	
	Pf=	4850	2900	2370	2500	1530			2950	
3800	SIZE=	800x400	600x400	600x400	600x400	600x400			600x400	
	V REINF.=	8-30M	8-25M	6-25M	6-25M	6-25M			8-25M	
	DL=	3500	3470	3990	1550	975	3260	1575	2150	
	LL=	800	740	985	340	190	860	450	475	
4700	Pf=	5600	5570	6525	2500	1530	5400	2670	3420	1590
	SIZE=	1000x400	1000x400	1200x400	600x400	600x400	1000x400 FND. WALL	600x400	600x400	600x400
	V REINF.=	8-35M	8-35M	10-30M	6-25M	6-25M	8-35M	6-25M	8-30M	6-25M
	BASEMENT									

NO.	1	ISSUED FOR PERMIT	20/03/30	M.S.	T.L.R.
		REVISION	DATE	BY	APPROVED
REVISIONS					
513 DUNDAS STREET EAST, WHITBY, ON KIYA DEVELOPMENTS LTD.					
<b>STRUCTURAL SCHEDULES</b>					
 <b>D.G. Biddle &amp; Associates Limited</b> <small>consulting engineers and planners</small> 96 KING STREET EAST • OSHAWA, ON L1H 1B6 PHONE (905)576-8500 • FAX (905)576-9730 info@dgbiddle.com					
SCALE:	AS SHOWN	PROJECT NO.	116194		
DRAWN BY:	M.A.S.	DRAWING NO.	S2		
DESIGN BY:	T.L.R.	CAD FILE:	-		
CHECKED BY:	D.D.B.	PLOT DATE:	20/06/22		
DATE:	JANUARY 2020	SUBMISSION PERMIT			

MARK		SIZE (WxD)	FLEXURAL REINFORCEMENT GRID		STIRRUPS			MARK		SIZE (WxD)	FLEXURAL REINFORCEMENT GRID		STIRRUPS				
			L=LEFT END R=RIGHT END T=THROUGHOUT REM=REMAINDER		REMARKS	SIZE	TYPE	SPACING			L=LEFT END R=RIGHT END T=THROUGHOUT REM=REMAINDER		REMARKS	SIZE	TYPE	SPACING	
BML1		400x600	B	C	F		10M		GRID B-C 10 @170L 14 @170R @300 REM  GRID C-F 10 @170L @300 REM	BML7		200x600					
BML2		400x600	B	C			10M		10 @170L 14 @170R @300 REM	BML8		300x1150					
BML3		400x600	B	C			10M		10 @170L 14 @170R @300 REM	BML9		200x600	1	2			
BML4		400x600	B	C	F		10M		GRID B-C 10 @170L 14 @170R @300 REM  GRID C-F 10 @170L @300 REM	BML10		400x1000	H	G	F		
BML5		200x600	PERIMETER BEAM B AND F, 2 AND 16				10M		@300 O/C	BML11		400x600	A	B			
BML6		200x600	2	16	1	17		10M		@300 O/C	BML12		600x1000	1	4		

1		ISSUED FOR PERMIT	20/03/30	M.S.	T.L.R.
NO.	REVISION	DATE	BY	APPROVED	
REVISIONS					
513 DUNDAS STREET EAST, WHITBY, ON KIYA DEVELOPMENTS LTD.					
<b>STRUCTURAL BEAM SCHEDULES</b>					
<b>D.G. Biddle &amp; Associates Limited</b> consulting engineers and planners					
96 KING STREET EAST • OSHAWA, ON L1H 1B6 PHONE (905)576-8500 • FAX (905)576-9730 info@dgibiddle.com					
SCALE:	AS SHOWN	PROJECT NO.	116194		
DRAWN BY:	M.A.S.	DRAWING NO.	S3		
DESIGN BY:	T.L.R.	CAD FILE:	-		
CHECKED BY:	D.D.B.	PLOT DATE:	20/06/22		
DATE:	JANUARY 2020	SUBMISSION:	PERMIT		

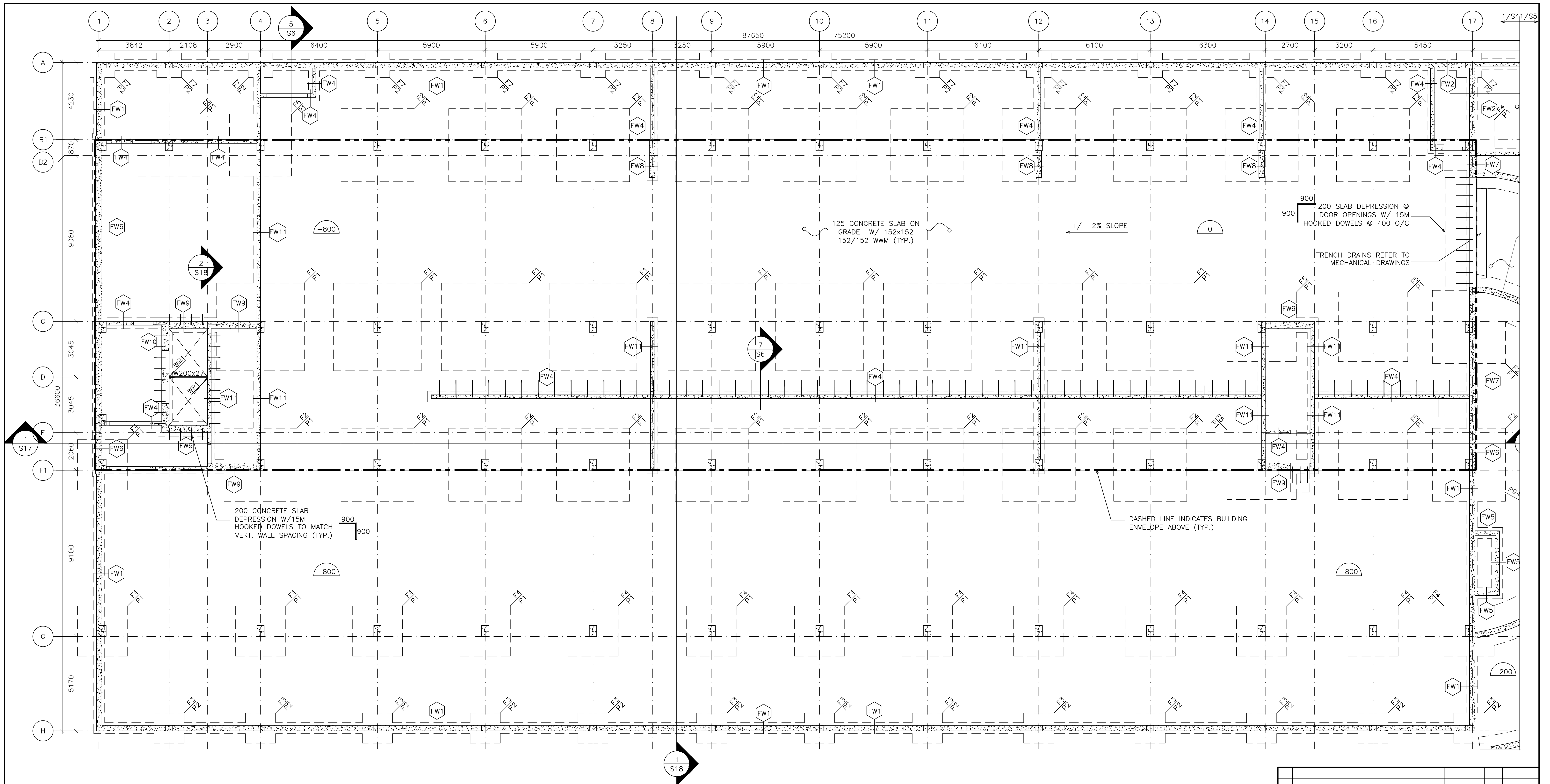

1 STRUCTURAL FOUNDATION PLAN (1/2)  
 S4 SCALE: 1:100

NOTE: SAWCUTS TO @ 3048x3048 MAX. FOR CRACK CONTROL OF SLAB AND AT COLUMN LOCATIONS.

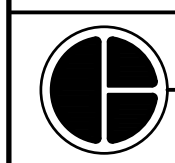
1	ISSUED FOR PERMIT	20/03/30	M.S. T.L.R.
NO.	REVISION	DATE	BY APPROVED
REVISIONS			
513 DUNDAS STREET EAST, WHITBY, ON KIYA DEVELOPMENTS LTD.			
<b>STRUCTURAL FOUNDATION PLAN (1/2)</b>			
 <b>D.G. Biddle &amp; Associates Limited</b> <small>consulting engineers and planners</small> <small>96 KING STREET EAST • OSHAWA, ON L1H 1B6</small> <small>PHONE (905)576-8500 • FAX (905)576-9730</small> <small>info@dgibiddle.com</small>			
SCALE:	AS SHOWN	PROJECT NO.	116194
DRAWN BY:	M.A.S.	DRAWING NO.	S4
DESIGN BY:	T.L.R.	CAD FILE:	-
CHECKED BY:	D.D.B.	PLOT DATE:	20/06/22
DATE:	JANUARY 2020	SUBMISSION:	PERMIT

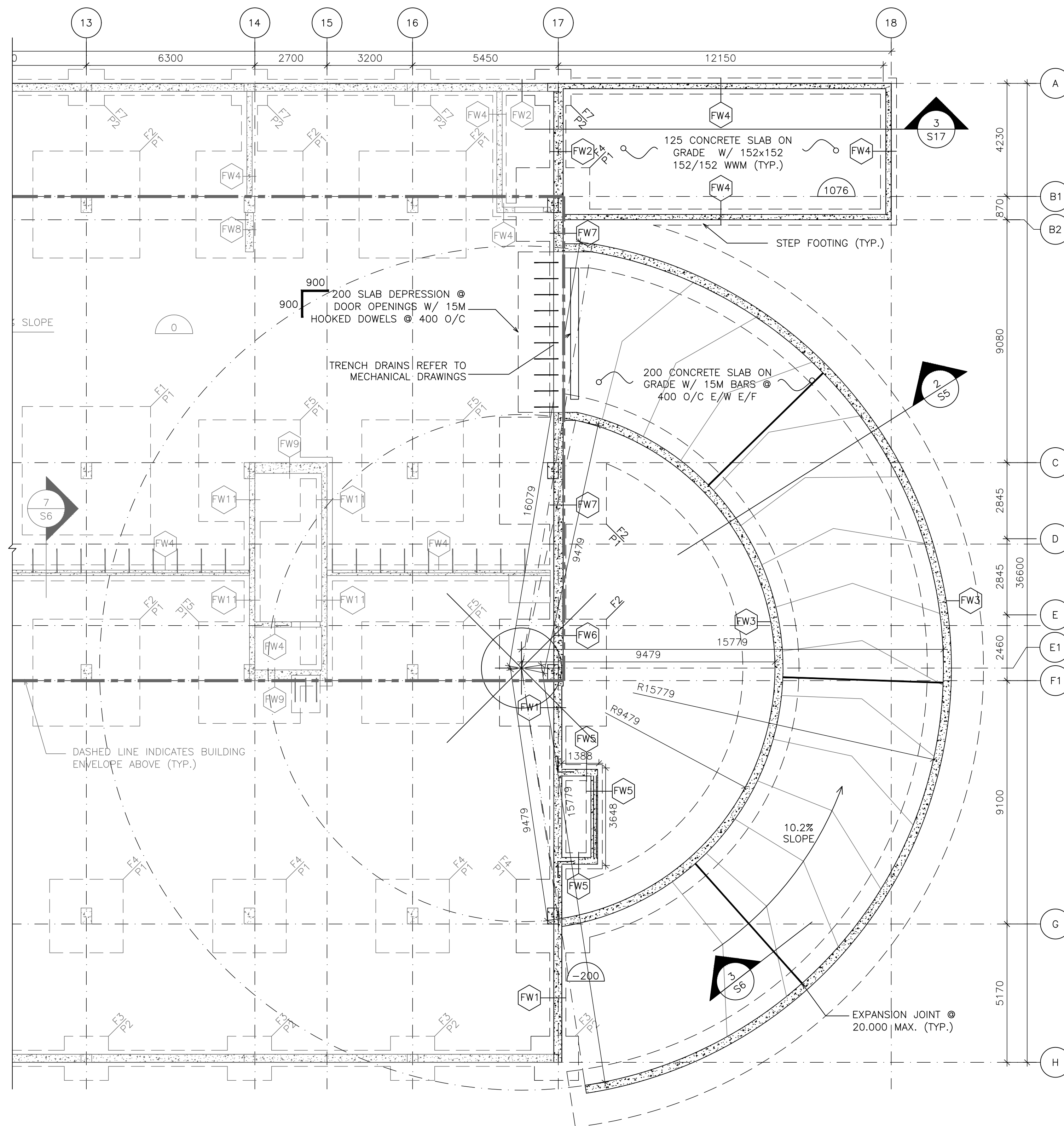

1 STRUCTURAL FOUNDATION PLAN - RAMP (2/2)  
S5 SCALE: 1:100

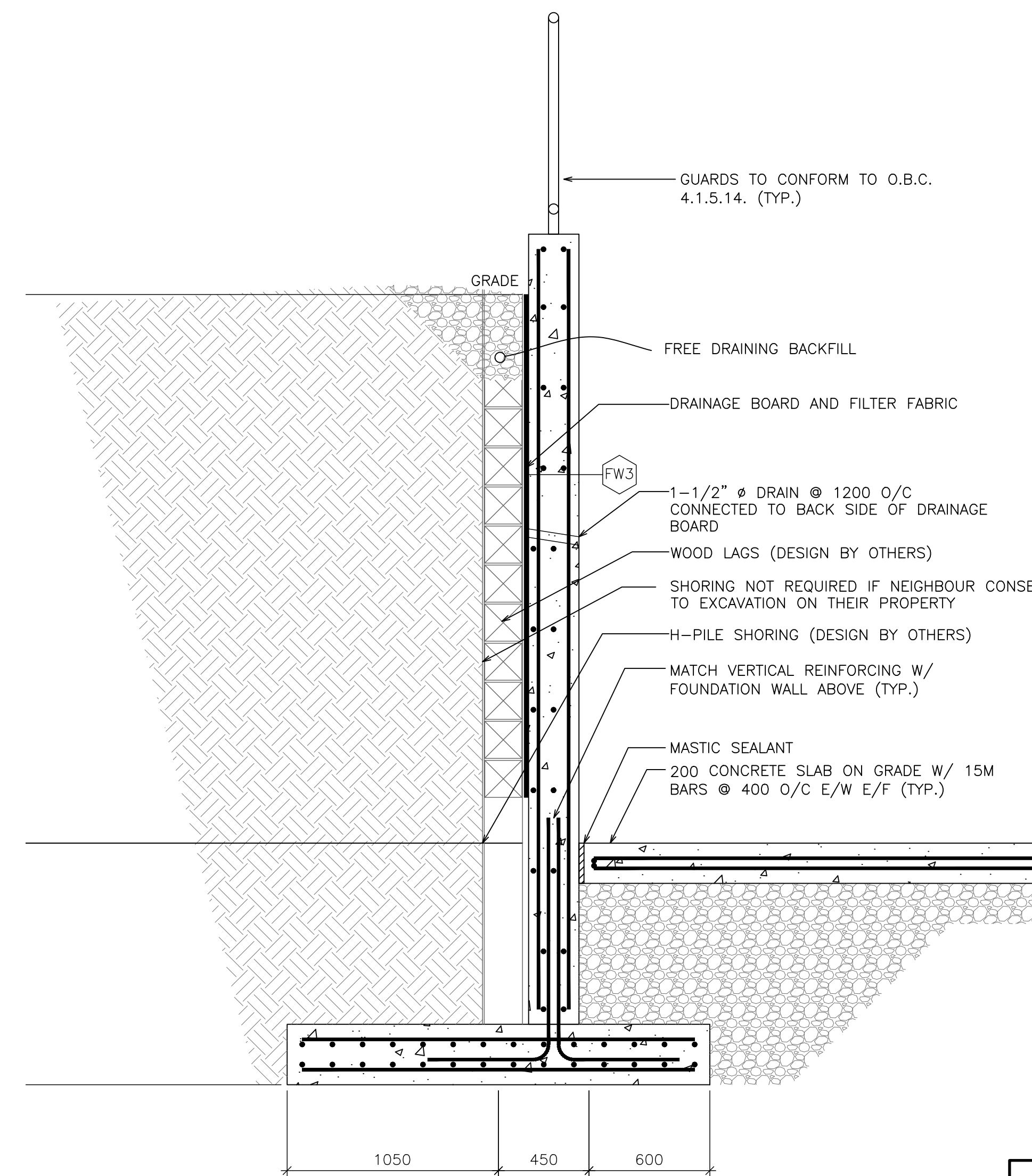

2 UNDERGROUND PARKING GARAGE RETAINING WALL DETAIL  
S5 SCALE: 1:20

1 ISSUED FOR PERMIT					20/03/30	M.S.	T.L.R.
NO.	REVISION	DATE	BY	APPROVED			
REVISIONS							
513 DUNDAS STREET EAST, WHITBY, ON KIYA DEVELOPMENTS LTD.							
<b>STRUCTURAL FOUNDATION PLAN - RAMP (2/2)</b>							
<b>D.G. Biddle &amp; Associates Limited</b> consulting engineers and planners							
96 KING STREET EAST • OSHAWA, ON L1H 1B6 PHONE (905)576-8500 • FAX (905)576-9730 info@dgbiddle.com							
SCALE: AS SHOWN		PROJECT NO. 116194					
DRAWN BY: M.A.S.		DRAWING NO. S5					
DESIGN BY: T.L.R.							
CHECKED BY: D.D.B.				CAD FILE: -			
DATE: JANUARY 2020				PLOT DATE: 20/06/22 SUBMISSION: PERMIT			

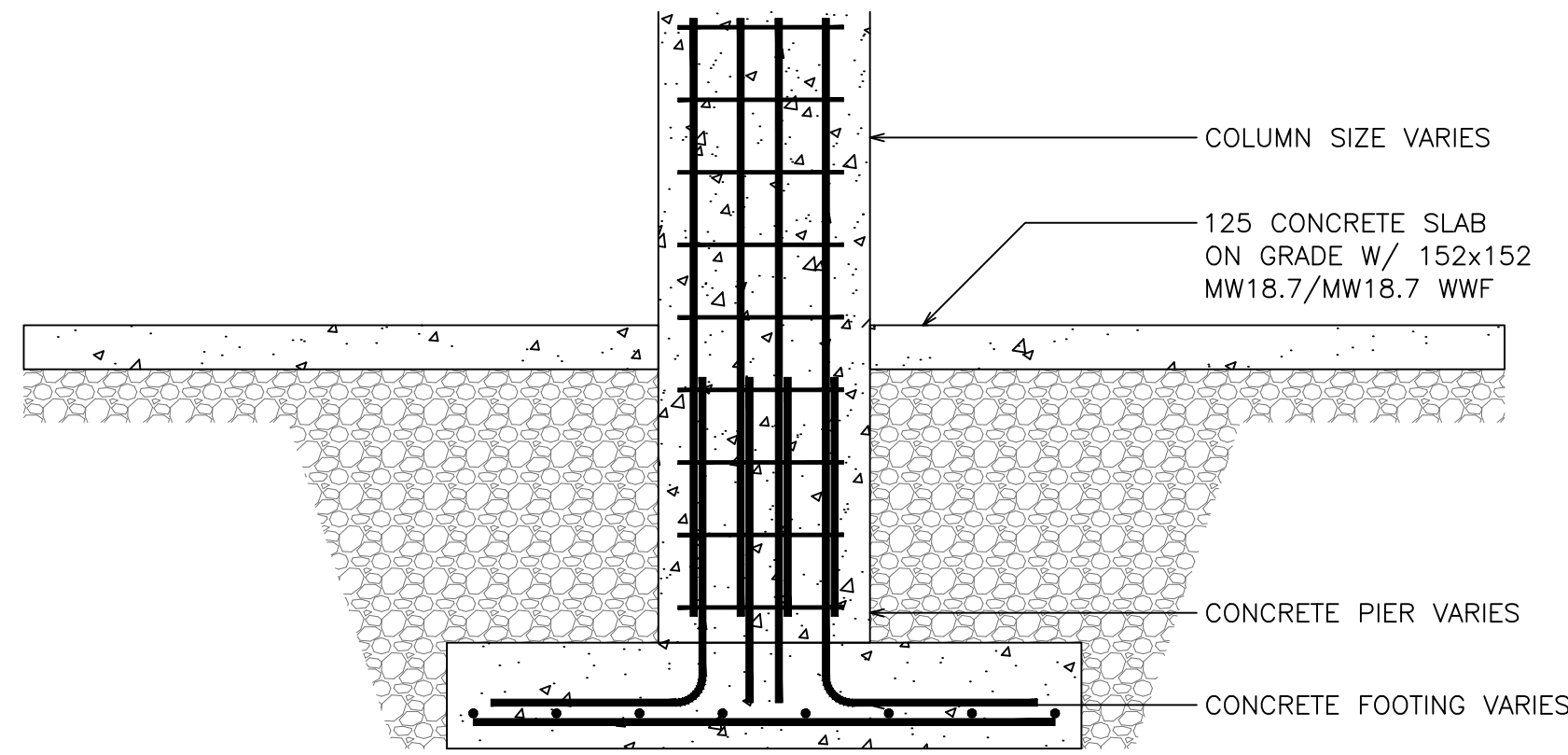

1 TYPICAL PIER AND FOOTING  
S6 SCALE: 1:20

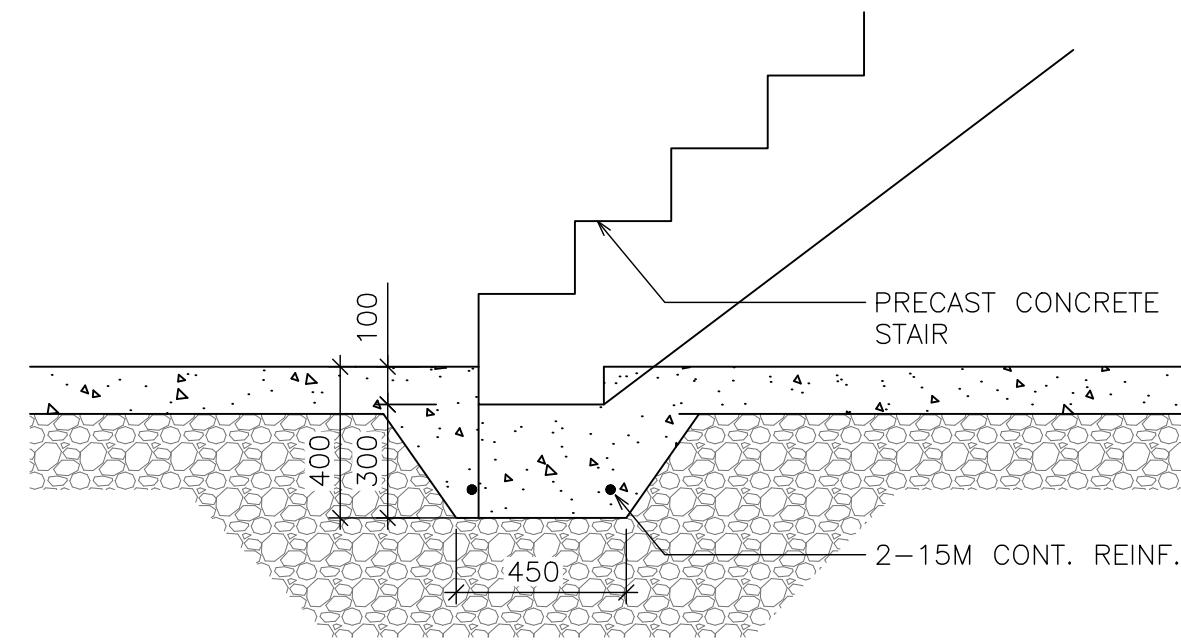

2 THICKENED SLAB FOR STAIR SUPPORT  
S6 SCALE: 1:20

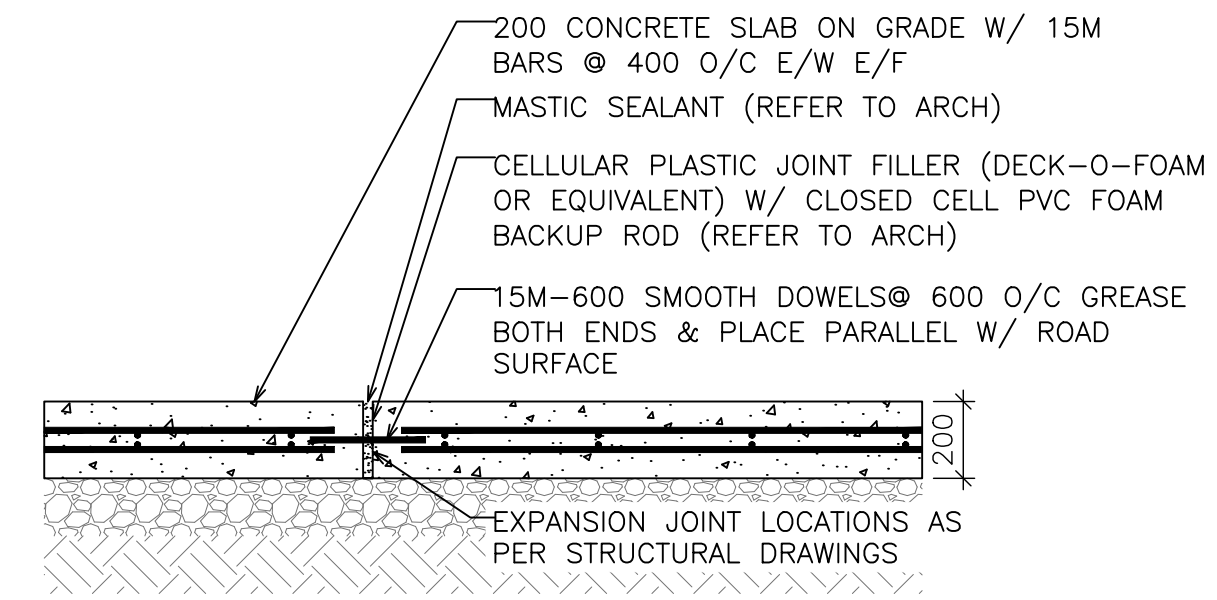

3 TYPICAL EXPANSION JOINT DETAIL  
S6 SCALE: 1:20

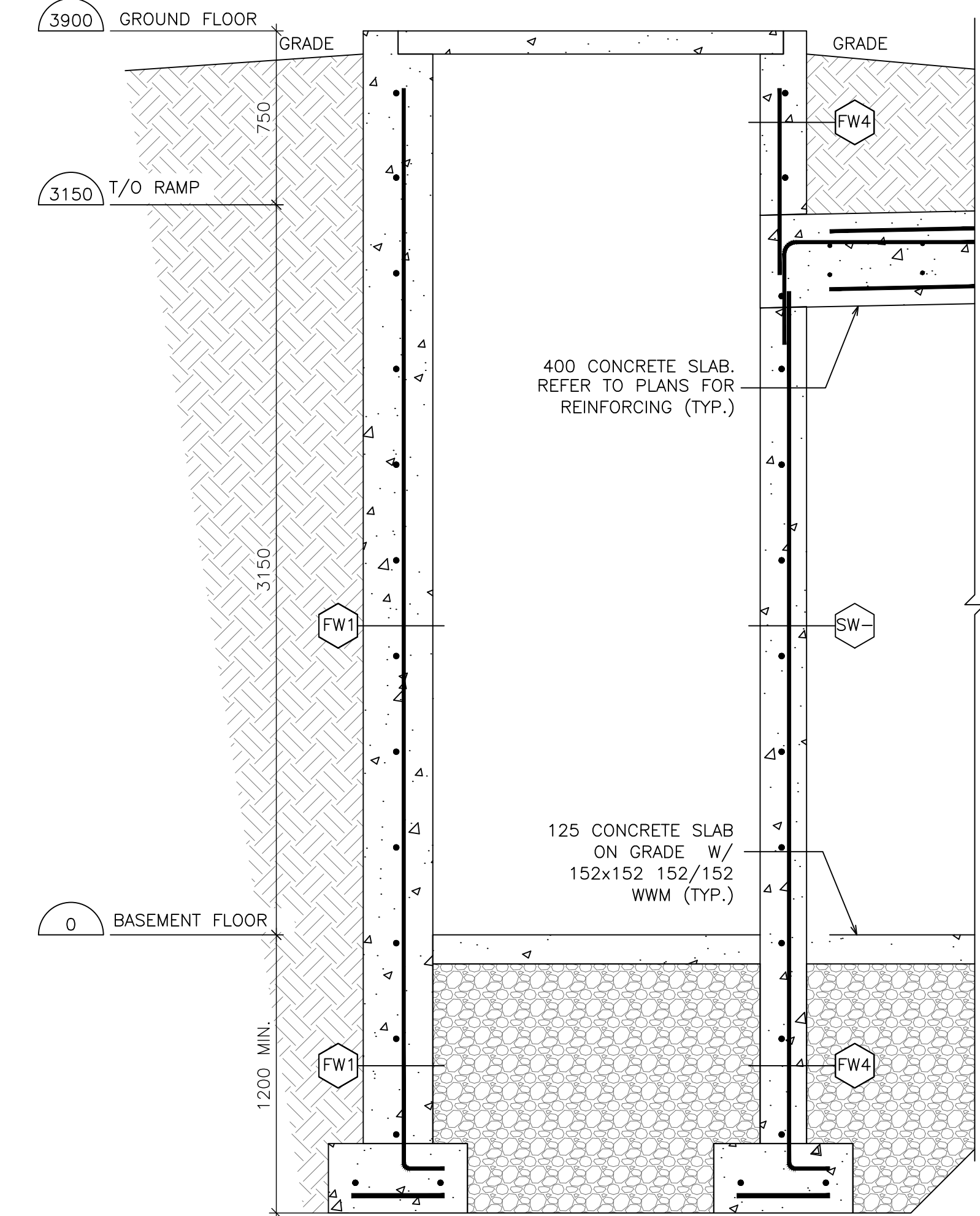

7 FOUNDATION DETAIL  
S6 SCALE: 1:20

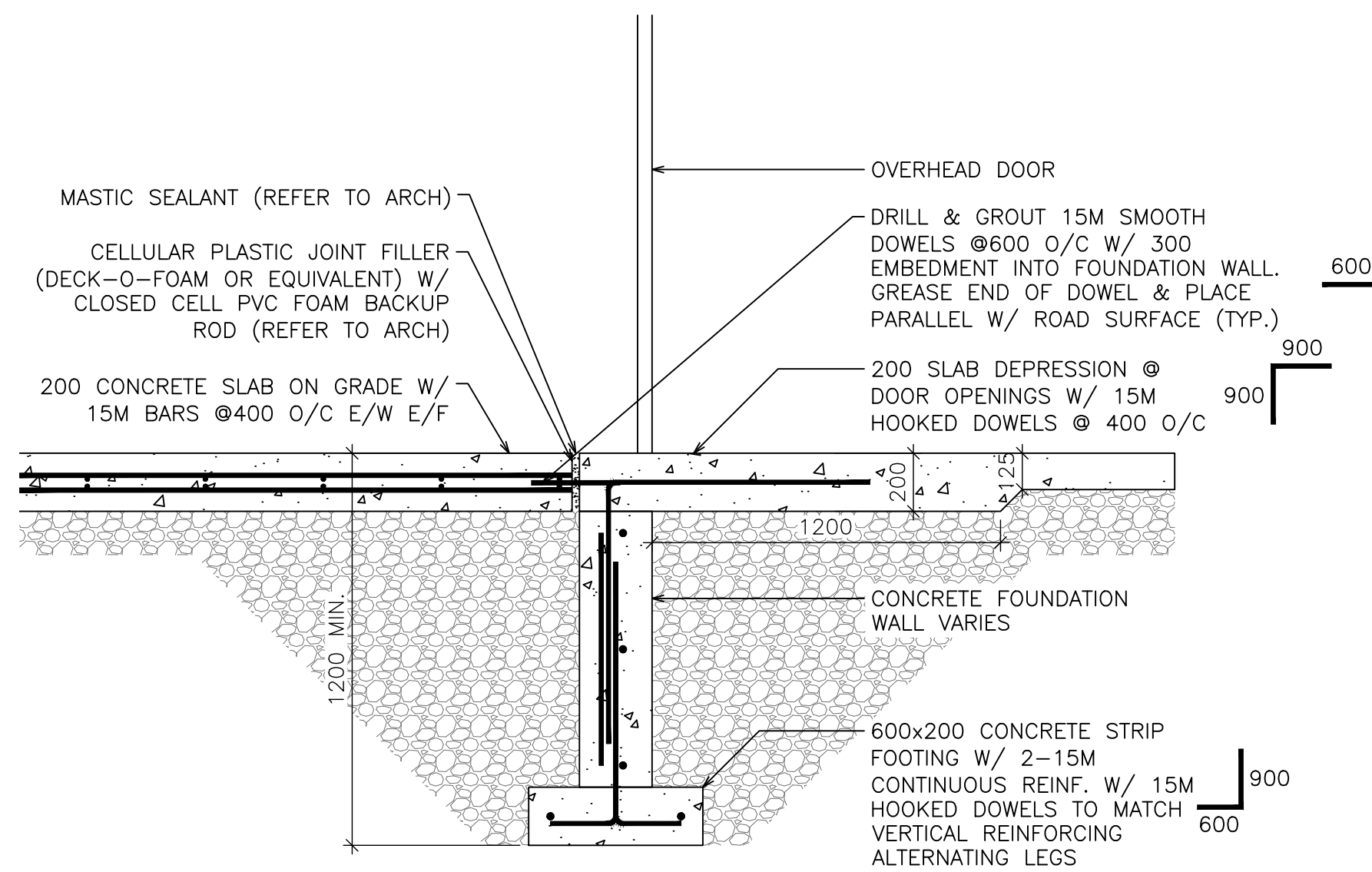

4 TYPICAL EXPANSION JOINT DETAIL AT BUILDING FOUNDATION  
S6 SCALE: 1:20

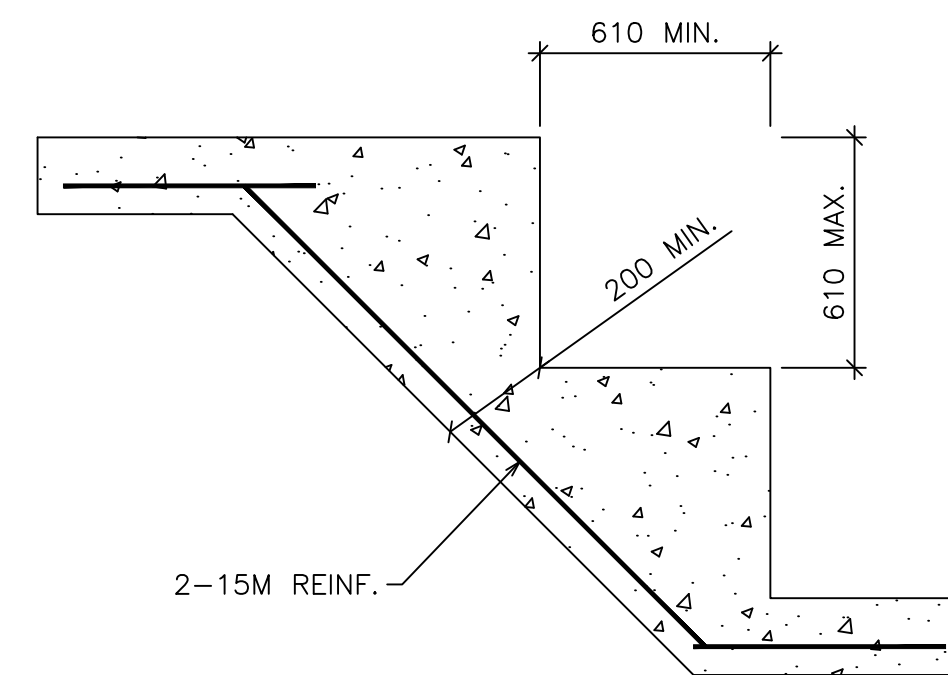

5 TYPICAL STRIP FOOTING DETAIL  
S6 SCALE: 1:20

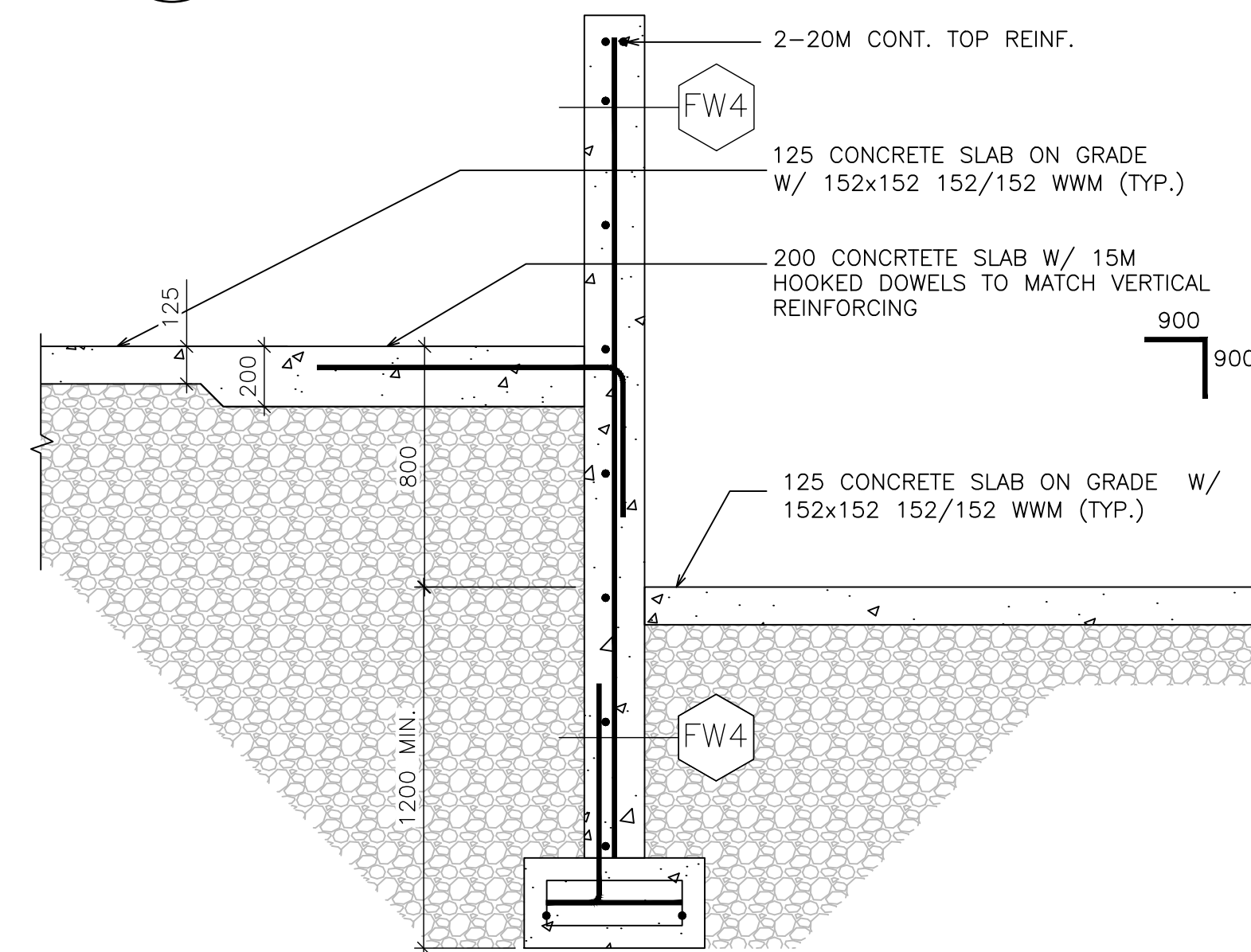

6 TYPICAL EXPANSION JOINT DETAIL  
S6 SCALE: 1:20

1	ISSUED FOR PERMIT	20/03/30	M.S. T.L.R.
NO.	REVISION	DATE	BY APPROVED
REVISIONS			
513 DUNDAS STREET EAST, WHITBY, ON KIYA DEVELOPMENTS LTD.			
<b>STRUCTURAL FOUNDATION DETAILS</b>			
 <b>D.G. Biddle &amp; Associates Limited</b> consulting engineers and planners			
96 KING STREET EAST • OSHAWA, ON L1H 1B6 PHONE (905)576-8500 • FAX (905)576-9730 info@dgbiddle.com			
SCALE:	AS SHOWN	PROJECT NO.	116194
DRAWN BY:	M.A.S.	DRAWING NO.	S6
DESIGN BY:	T.L.R.	CAD FILE:	-
CHECKED BY:	D.D.B.	PLOT DATE:	20/06/22
DATE:	JANUARY 2020	SUBMISSION:	PERMIT

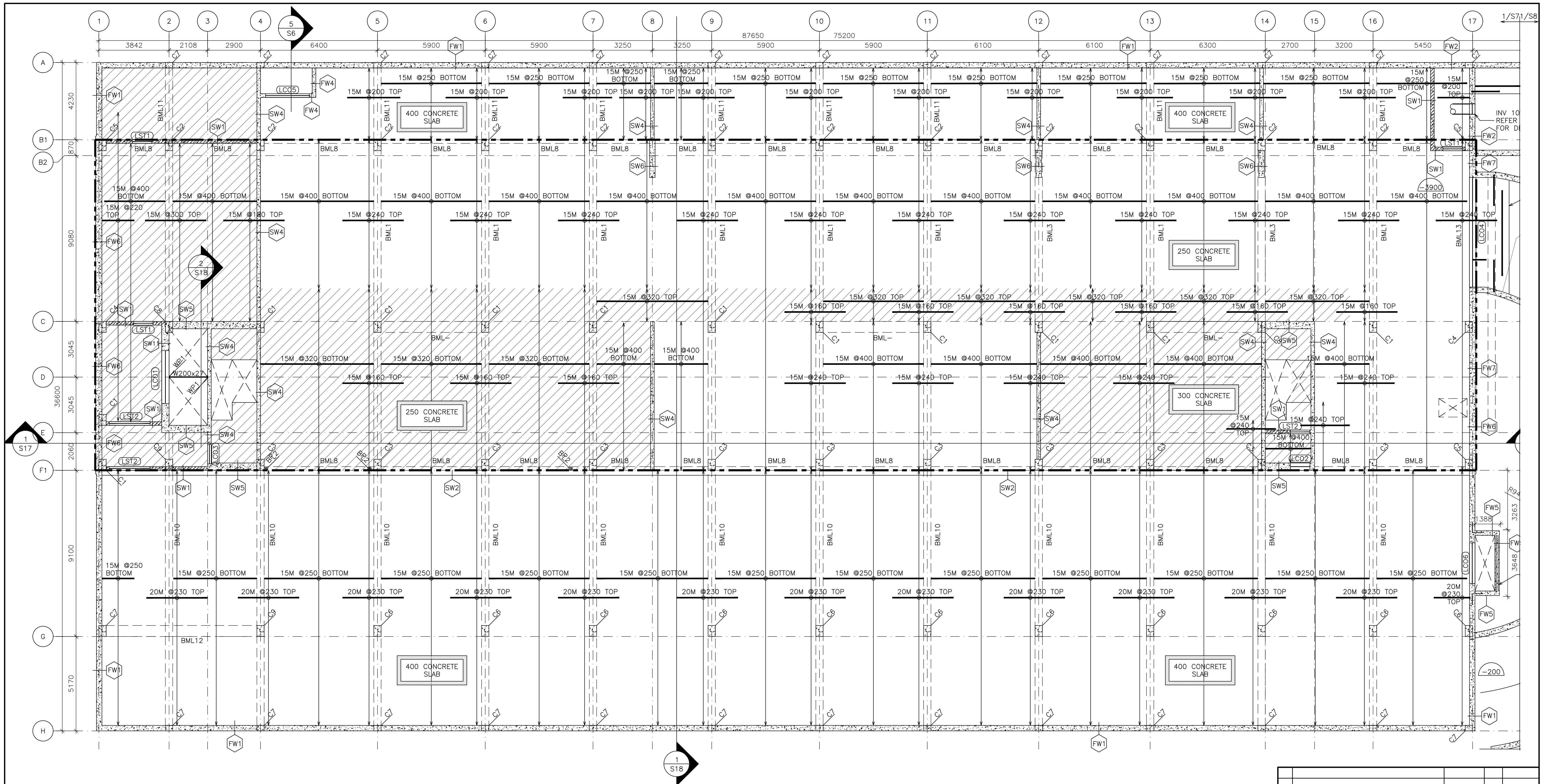

1 STRUCTURAL MAIN FLOOR PLAN (1/2)  
 S7 SCALE: 1:100

1 ISSUED FOR PERMIT				20/03/30	M.S.	T.L.R.
NO.	REVISION	DATE	BY	APPROVED		
REVISIONS						
513 DUNDAS STREET EAST, WHITBY, ON KIYA DEVELOPMENTS LTD.						
<b>STRUCTURAL MAIN FLOOR PLAN (1/2)</b>						
 <b>D.G. Biddle &amp; Associates Limited</b> consulting engineers and planners 96 KING STREET EAST • OSHAWA, ON L1H 1B6 PHONE (905) 576-8500 • FAX (905) 576-9730 info@dgbiddle.com						
SCALE:	AS SHOWN	PROJECT NO.	116194			
DRAWN BY:	M.A.S.	DRAWING NO.	S7			
DESIGN BY:	T.L.R.	CAD FILE:	-			
CHECKED BY:	D.D.B.	PLOT DATE:	20/06/22			
DATE:	JANUARY 2020	SUBMISSION:	PERMIT			

 HATCHED AREAS SHOWS PUBLIC LOAD LOCATIONS

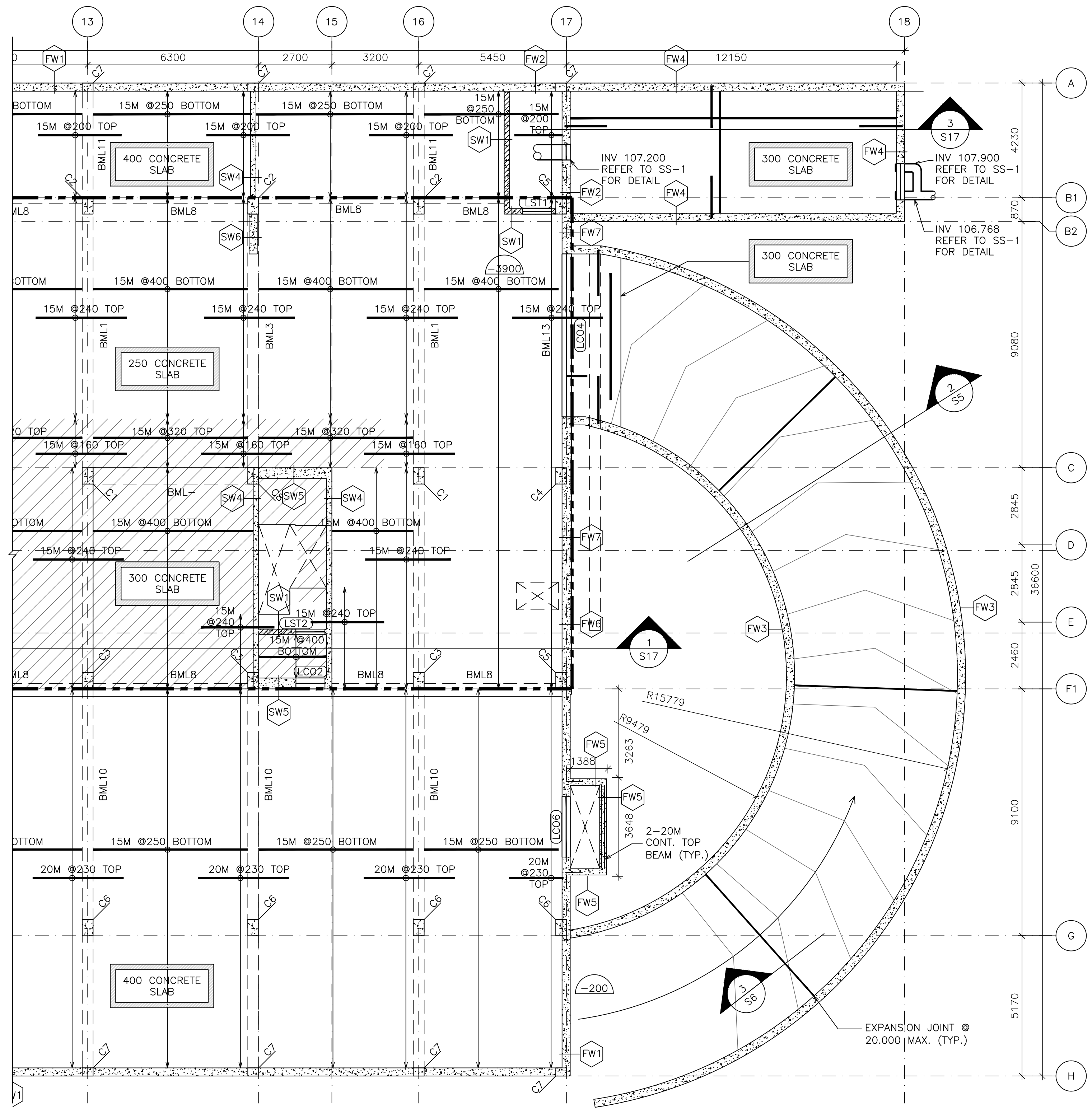

1 STRUCTURAL MAIN FLOOR PLAN - RAMP (2/2)  
 S8 SCALE: 1:100

HATCHED AREAS SHOWS PUBLIC LOAD LOCATIONS

1	ISSUED FOR PERMIT	20/03/30	M.S. T.L.R.
NO.	REVISION	DATE	BY APPROVED
REVISIONS			
513 DUNDAS STREET EAST, WHITBY, ON KIYA DEVELOPMENTS LTD.			
STRUCTURAL MAIN FLOOR PLAN (2/2)			
<b>D.G. Biddle &amp; Associates Limited</b> consulting engineers and planners 96 KING STREET EAST • OSHAWA, ON L1H 1B6 PHONE (905)576-8500 • FAX (905)576-9730 info@dgbiddle.com			
SCALE:	AS SHOWN	PROJECT NO.	116194
DRAWN BY:	M.A.S.	DRAWING NO.	S8
DESIGN BY:	T.L.R.	CAD FILE:	-
CHECKED BY:	D.D.B.	PLOT DATE:	20/06/22
DATE:	JANUARY 2020	SUBMISSION:	PERMIT



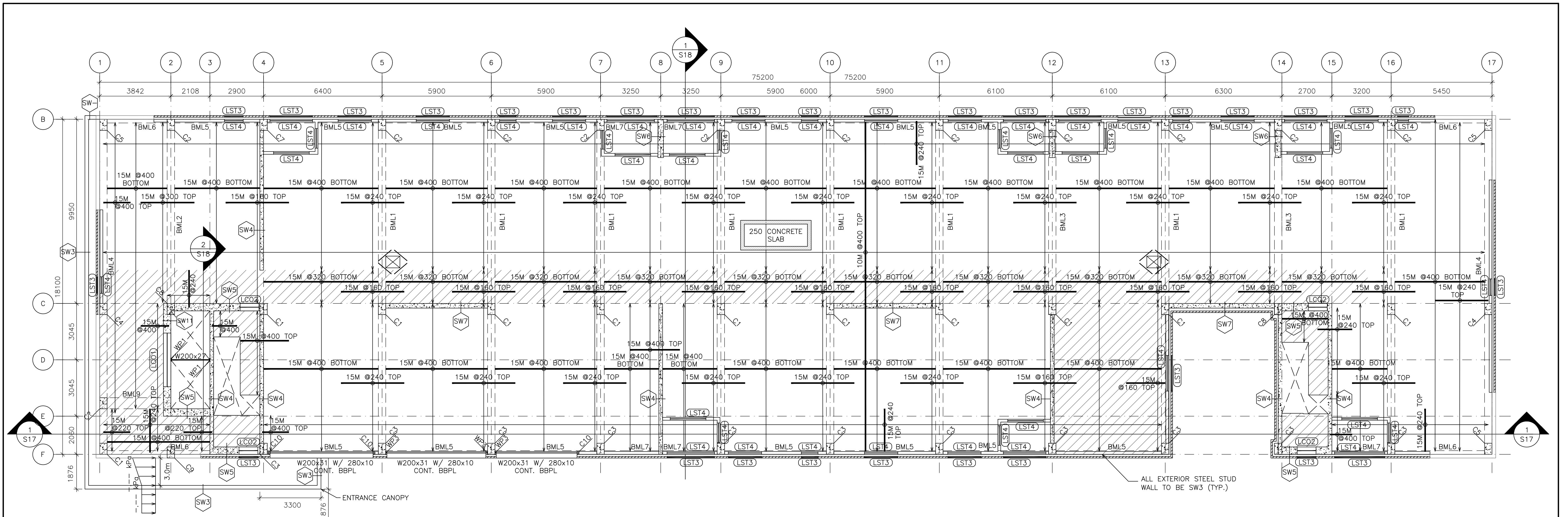

1 STRUCTURAL SECOND FLOOR PLAN  
S9 SCALE: 1:100

HATCHED AREAS SHOWS PUBLIC LOAD LOCATIONS

1 ISSUED FOR PERMIT				20/03/30	M.S.	T.L.R.
NO.	REVISION	DATE	BY	APPROVED		
REVISIONS						
513 DUNDAS STREET EAST, WHITBY, ON KIYA DEVELOPMENTS LTD.						
<b>STRUCTURAL SECOND FLOOR PLAN</b>						
<b>D.G. Biddle &amp; Associates Limited</b> consulting engineers and planners 96 KING STREET EAST • OSHAWA, ON L1H 1B6 PHONE (905)576-8500 • FAX (905)576-9730 info@dgibiddle.com						
SCALE: AS SHOWN		PROJECT NO. 116194				
DRAWN BY: M.A.S.		DRAWING NO. S9				
DESIGN BY: T.L.R.		CAD FILE: -				
CHECKED BY: D.D.B.		PLOT DATE: 20/06/22				
DATE: JANUARY 2020		SUBMISSION PERMIT				

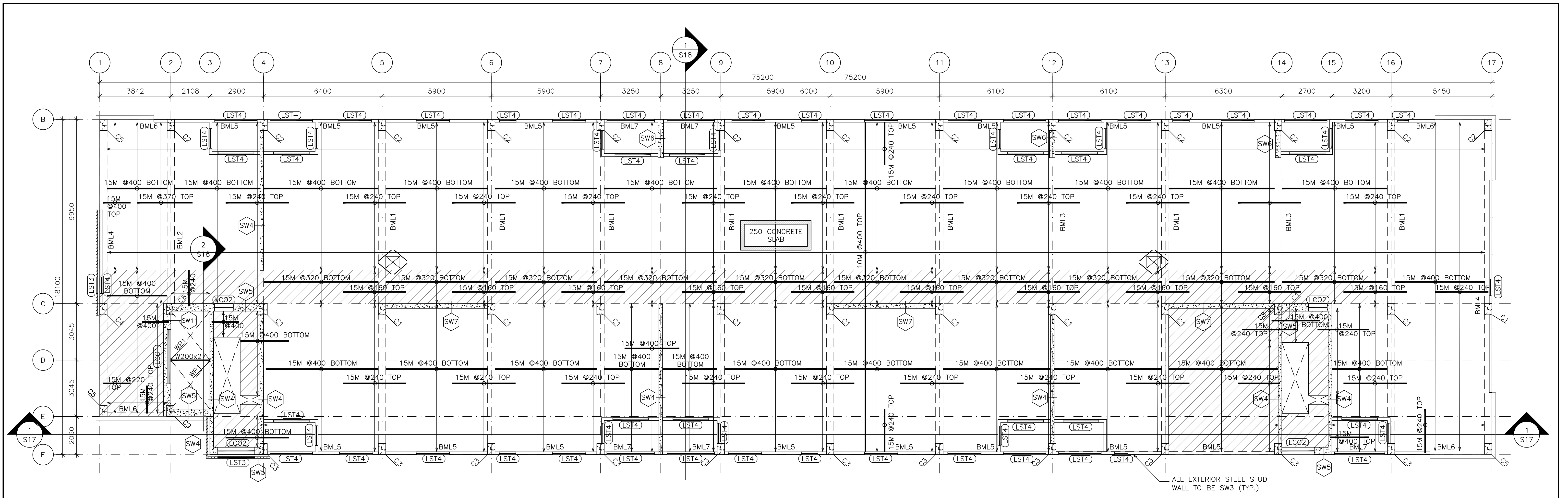

1 STRUCTURAL THIRD FLOOR PLAN  
 S10 SCALE: 1:100

1 ISSUED FOR PERMIT				20/03/30	M.S.	T.L.R.
NO.	REVISION	DATE	BY	APPROVED		
REVISIONS						
513 DUNDAS STREET EAST, WHITBY, ON KIYA DEVELOPMENTS LTD.						
<b>STRUCTURAL THIRD FLOOR PLAN</b>						
<b>D.G. Biddle &amp; Associates Limited</b> <i>consulting engineers and planners</i> 96 KING STREET EAST • OSHAWA, ON L1H 1B6 PHONE (905)576-8500 • FAX (905)576-9730 info@dgbiddle.com						
SCALE: AS SHOWN		PROJECT NO. 116194				
DRAWN BY: M.A.S.		DRAWING NO. S10				
DESIGN BY: T.L.R.		CAD FILE: -				
CHECKED BY: D.D.B.		PLOT DATE: 20/06/22				
DATE: JANUARY 2020		SUBMISSION PERMIT				

HATCHED AREAS SHOWS PUBLIC LOAD LOCATIONS

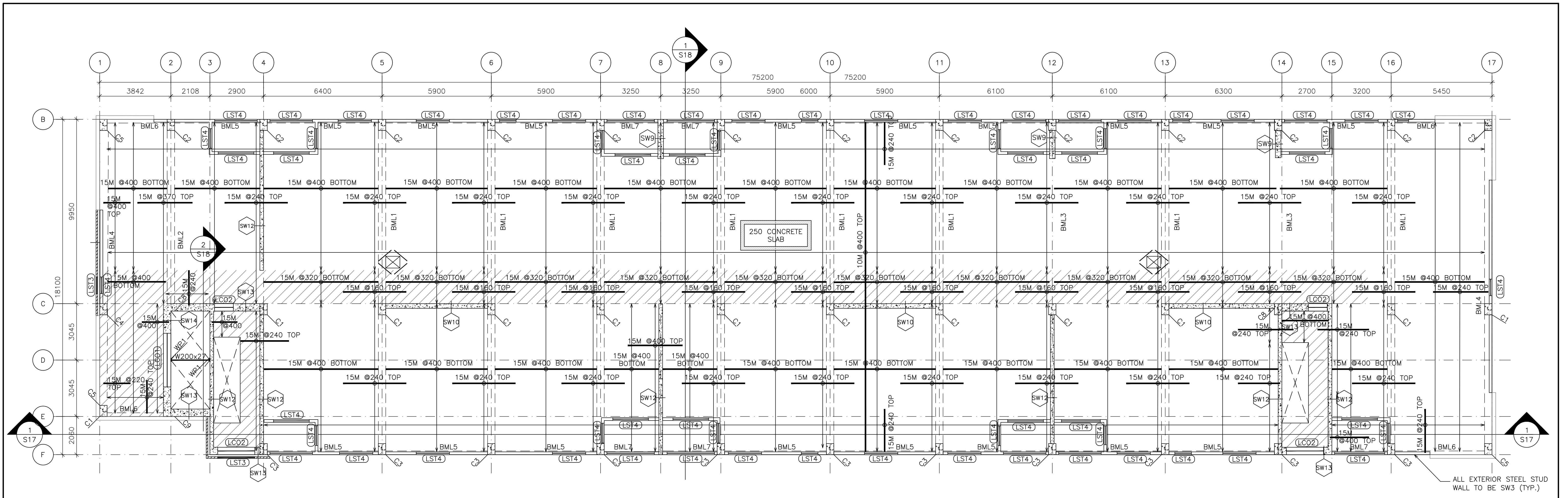

ALL EXTERIOR STEEL STUD WALL TO BE SW3 (TYP.)

1 STRUCTURAL FOURTH FLOOR PLAN  
 S11 SCALE: 1:100

HATCHED AREAS SHOWS PUBLIC LOAD LOCATIONS

1 ISSUED FOR PERMIT				20/03/30	M.S.	T.L.R.
NO.	REVISION	DATE	BY	APPROVED		
REVISIONS						
513 DUNDAS STREET EAST, WHITBY, ON KIYA DEVELOPMENTS LTD.						
<b>STRUCTURAL FOURTH FLOOR PLAN</b>						
<b>D.G. Biddle &amp; Associates Limited</b> consulting engineers and planners 96 KING STREET EAST • OSHAWA, ON L1H 1B6 PHONE (905)576-8500 • FAX (905)576-9730 info@dgbiddle.com						
SCALE: AS SHOWN		PROJECT NO. 116194				
DRAWN BY: M.A.S.		DRAWING NO. S11				
DESIGN BY: T.L.R.		CAD FILE: -				
CHECKED BY: D.D.B.		PLOT DATE: 20/06/22				
DATE: JANUARY 2020		SUBMISSION PERMIT				

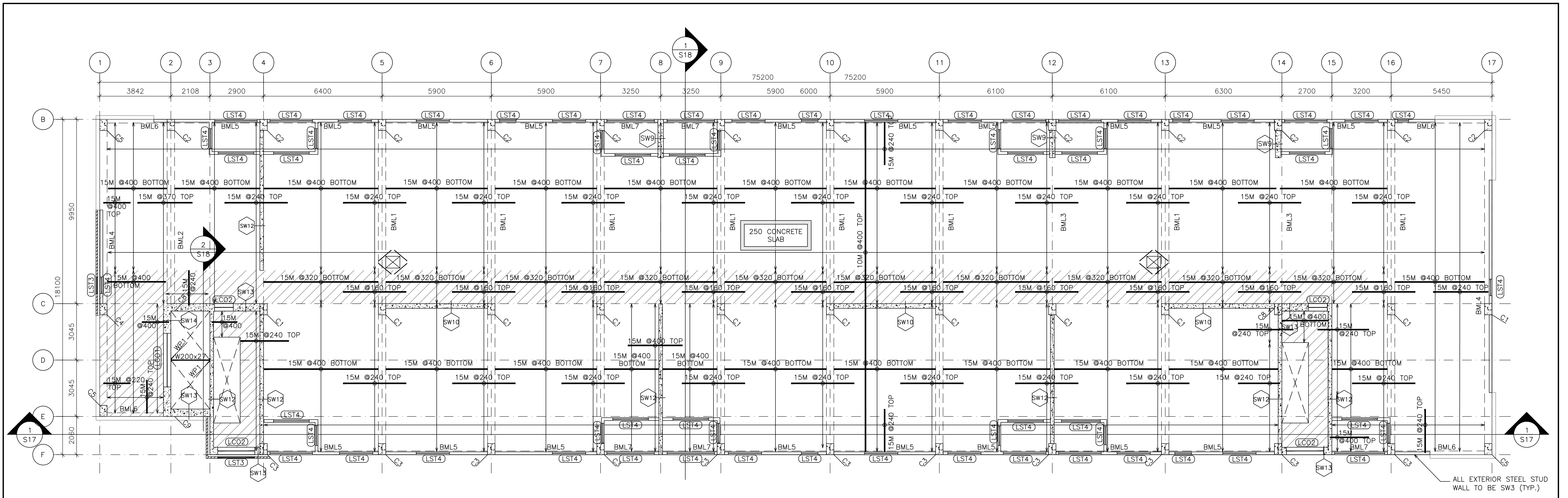

ALL EXTERIOR STEEL STUD WALL TO BE SW3 (TYP.)

1 STRUCTURAL FIFTH FLOOR PLAN  
 S12 SCALE: 1:100

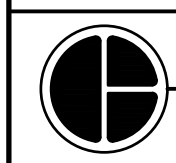
1 ISSUED FOR PERMIT				20/03/30	M.S.	T.L.R.
NO.	REVISION	DATE	BY	APPROVED		
REVISIONS						
513 DUNDAS STREET EAST, WHITBY, ON KIYA DEVELOPMENTS LTD.						
STRUCTURAL FIFTH FLOOR PLAN						
 <b>D.G. Biddle &amp; Associates Limited</b> consulting engineers and planners 96 KING STREET EAST • OSHAWA, ON L1H 1B6 PHONE (905)576-8500 • FAX (905)576-9730 info@dgbiddle.com						
SCALE: AS SHOWN		PROJECT NO. 116194				
DRAWN BY: M.A.S.		DRAWING NO. S12				
DESIGN BY: T.L.R.		CAD FILE: -				
CHECKED BY: D.D.B.		PLOT DATE: 20/06/22				
DATE: JANUARY 2020		SUBMISSION PERMIT				

 HATCHED AREAS SHOWS PUBLIC LOAD LOCATIONS

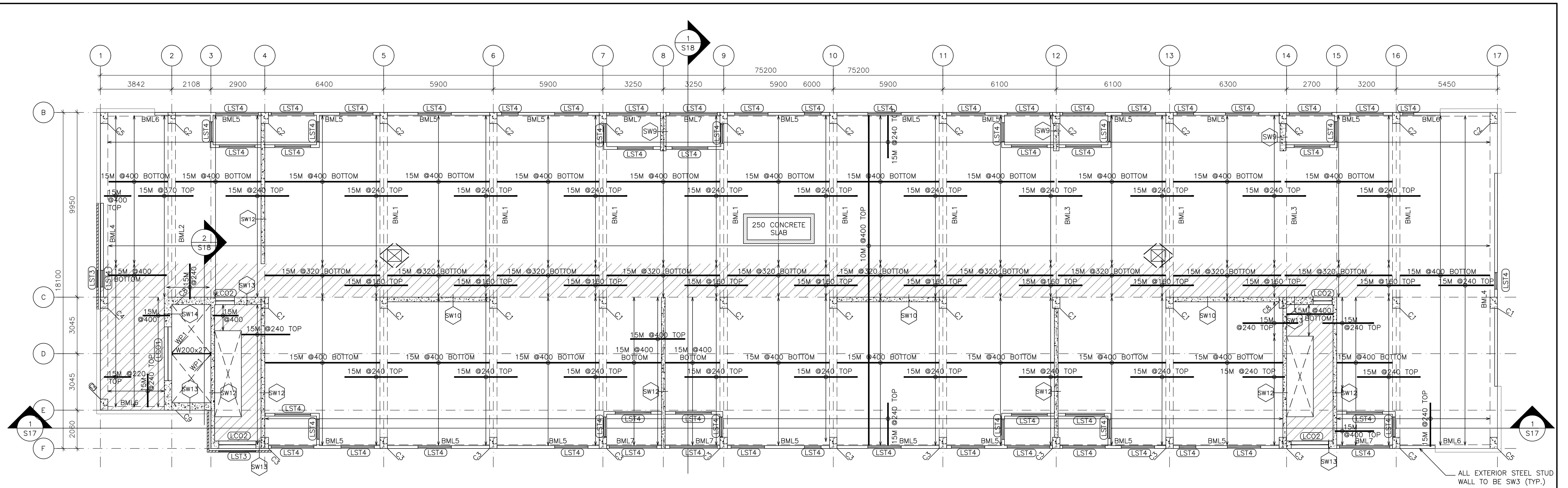

1 STRUCTURAL SIXTH FLOOR PLAN  
 S13 SCALE: 1:100

HATCHED AREAS SHOWS PUBLIC LOAD LOCATIONS

1 ISSUED FOR PERMIT				20/03/30	M.S.	T.L.R.
NO.	REVISION	DATE	BY	APPROVED		
REVISIONS						
513 DUNDAS STREET EAST, WHITBY, ON KIYA DEVELOPMENTS LTD.						
<b>STRUCTURAL SIXTH FLOOR PLAN</b>						
<b>D.G. Biddle &amp; Associates Limited</b> consulting engineers and planners 96 KING STREET EAST • OSHAWA, ON L1H 1B6 PHONE (905)576-8500 • FAX (905)576-9730 info@dgibiddle.com						
SCALE:	AS SHOWN	PROJECT NO.	116194			
DRAWN BY:	M.A.S.	DRAWING NO.	S13			
DESIGN BY:	T.L.R.	CAD FILE:	-			
CHECKED BY:	D.D.B.	PLOT DATE:	20/06/22			
DATE:	JANUARY 2020	SUBMISSION:	PERMIT			

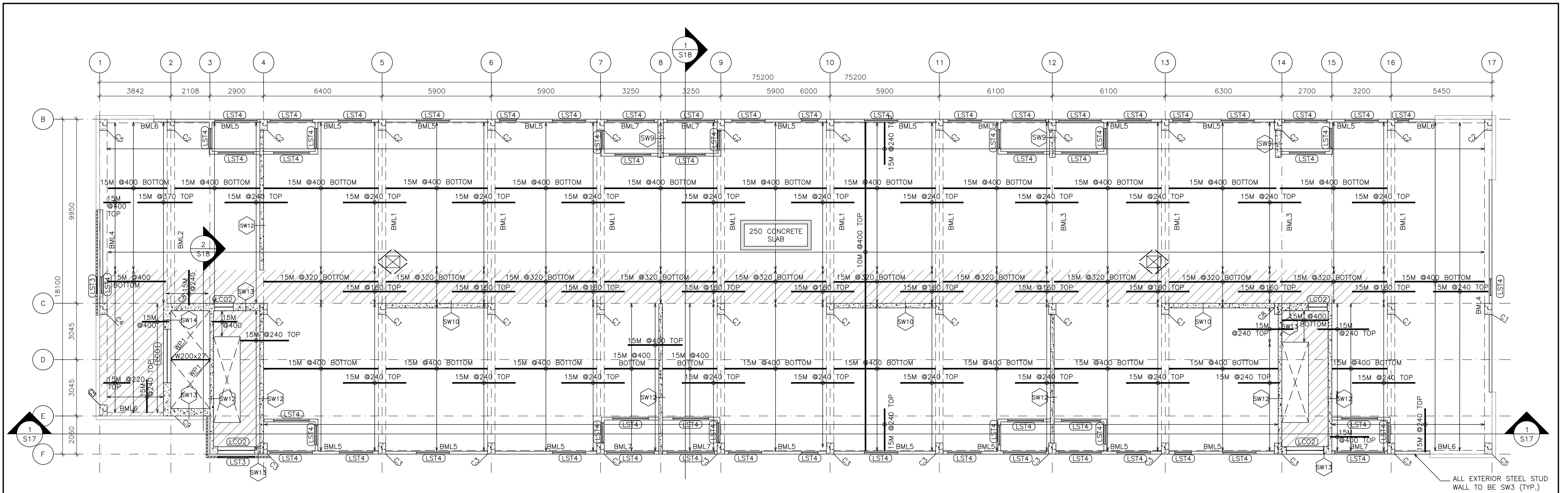

1 STRUCTURAL ROOF PLAN  
S14 SCALE: 1:100

HATCHED AREAS SHOWS PUBLIC LOAD LOCATIONS

1 ISSUED FOR SUBMITTAL FOR PERMIT		20/01/20	R.G.	D.D.B.
NO.	REVISION	DATE	BY	APPROVED
REVISIONS				
513 DUNDAS STREET EAST, WHITBY, ON KIYA DEVELOPMENTS LTD.				
<b>STRUCTURAL ROOF PLAN</b>				
<b>D.G. Biddle &amp; Associates Limited</b> consulting engineers and planners 96 KING STREET EAST - OSHAWA, ON L1H 1B6 PHONE (905) 576-8500 • FAX (905) 576-9730 info@dgibiddle.com				
SCALE:	AS SHOWN	PROJECT NO.	116194	
DRAWN BY:	M.A.S.	DRAWING NO.	S14	
DESIGN BY:	T.L.R.	CAD FILE: -	PLOT DATE: 20/06/22	
CHECKED BY:	D.D.B.	DATE:	JANUARY 2020	
DATE:	JANUARY 2020	SUBMISSION PERMIT		

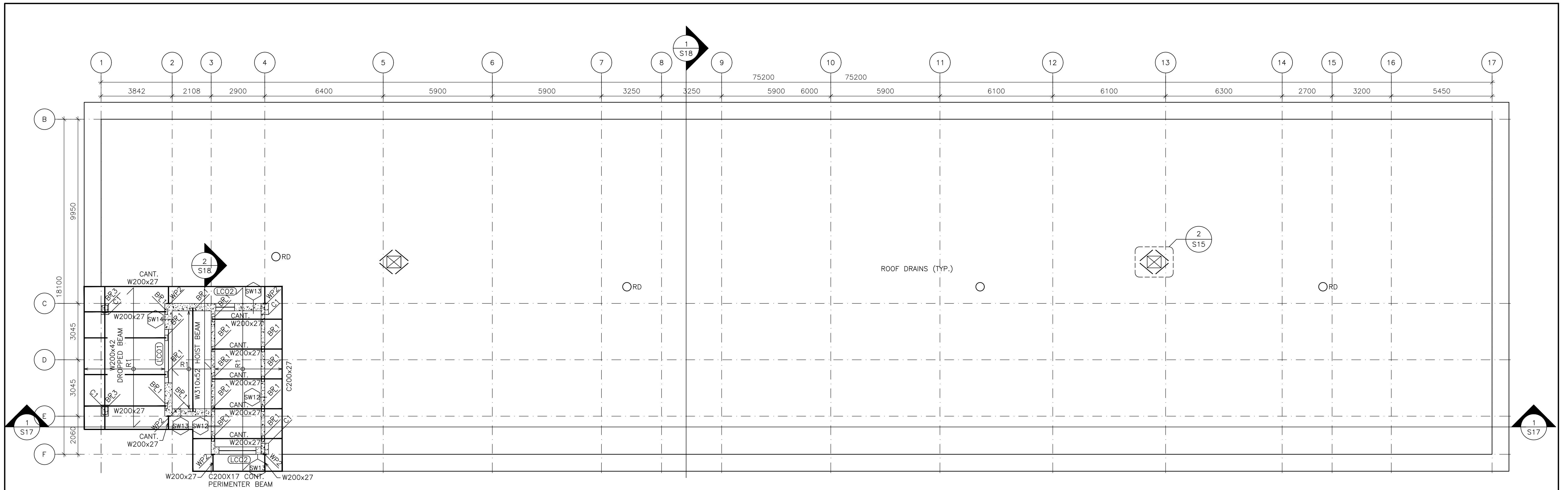

1 PENTHOUSE ROOF PLAN  
S15 SCALE: 1:100

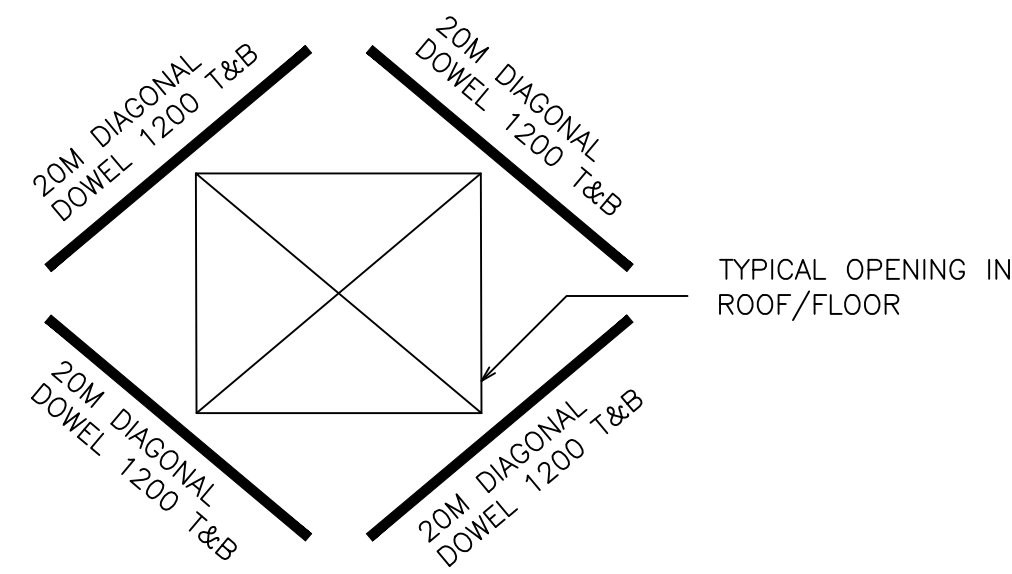

2 TYPICAL OPENING IN ROOF/FLOOR DETAIL  
S15 SCALE: 1:100

1	ISSUED FOR PERMIT	20/03/30	M.S. T.L.R.
NO.	REVISION	DATE	BY APPROVED
REVISIONS			
513 DUNDAS STREET EAST, WHITBY, ON KIYA DEVELOPMENTS LTD.			
<b>STRUCTURAL PENTHOUSE PLAN</b>			
 <b>D.G. Biddle &amp; Associates Limited</b> consulting engineers and planners 96 KING STREET EAST • OSHAWA, ON L1H 1B6 PHONE (905)576-8500 • FAX (905)576-9730 info@dgibiddle.com			
SCALE:	AS SHOWN	PROJECT NO.	116194
DRAWN BY:	M.A.S.	DRAWING NO.	S15
DESIGN BY:	T.L.R.	CAD FILE: -	
CHECKED BY:	D.D.B.	PLOT DATE: 20/06/22	
DATE:	JANUARY 2020	SUBMISSION: PERMIT	

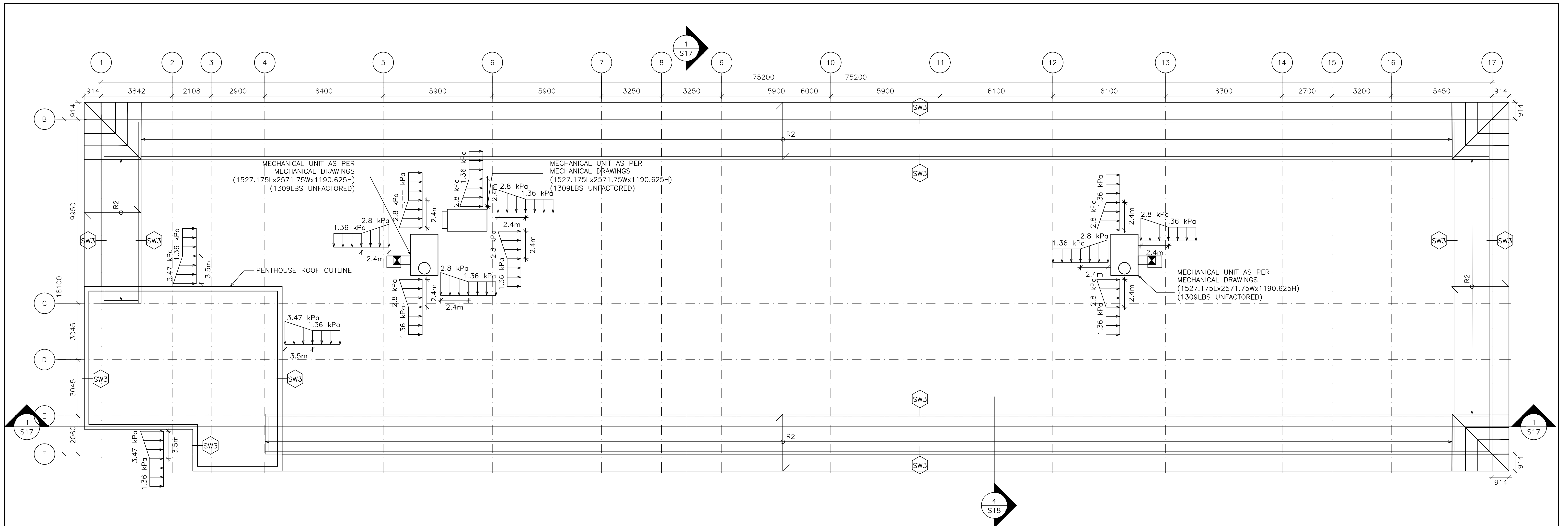

1 ROOF LOADS PLAN  
S16 SCALE: 1:100

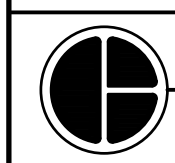
1	ISSUED FOR PERMIT	20/03/30	M.S. T.L.R.
NO.	REVISION	DATE	BY APPROVED
REVISIONS			
513 DUNDAS STREET EAST, WHITBY, ON KIYA DEVELOPMENTS LTD.			
<b>STRUCTURAL ROOF LOADS PLAN</b>			
 <b>D.G. Biddle &amp; Associates Limited</b> consulting engineers and planners 96 KING STREET EAST • OSHAWA, ON L1H 1B6 PHONE (905)576-8500 • FAX (905)576-9730 info@dgibiddle.com			
SCALE:	AS SHOWN	PROJECT NO.	116194
DRAWN BY:	M.A.S.	DRAWING NO.	S16
DESIGN BY:	T.L.R.	CAD FILE:	-
CHECKED BY:	D.D.B.	PLOT DATE:	20/06/22
DATE:	JANUARY 2020	SUBMISSION:	S16



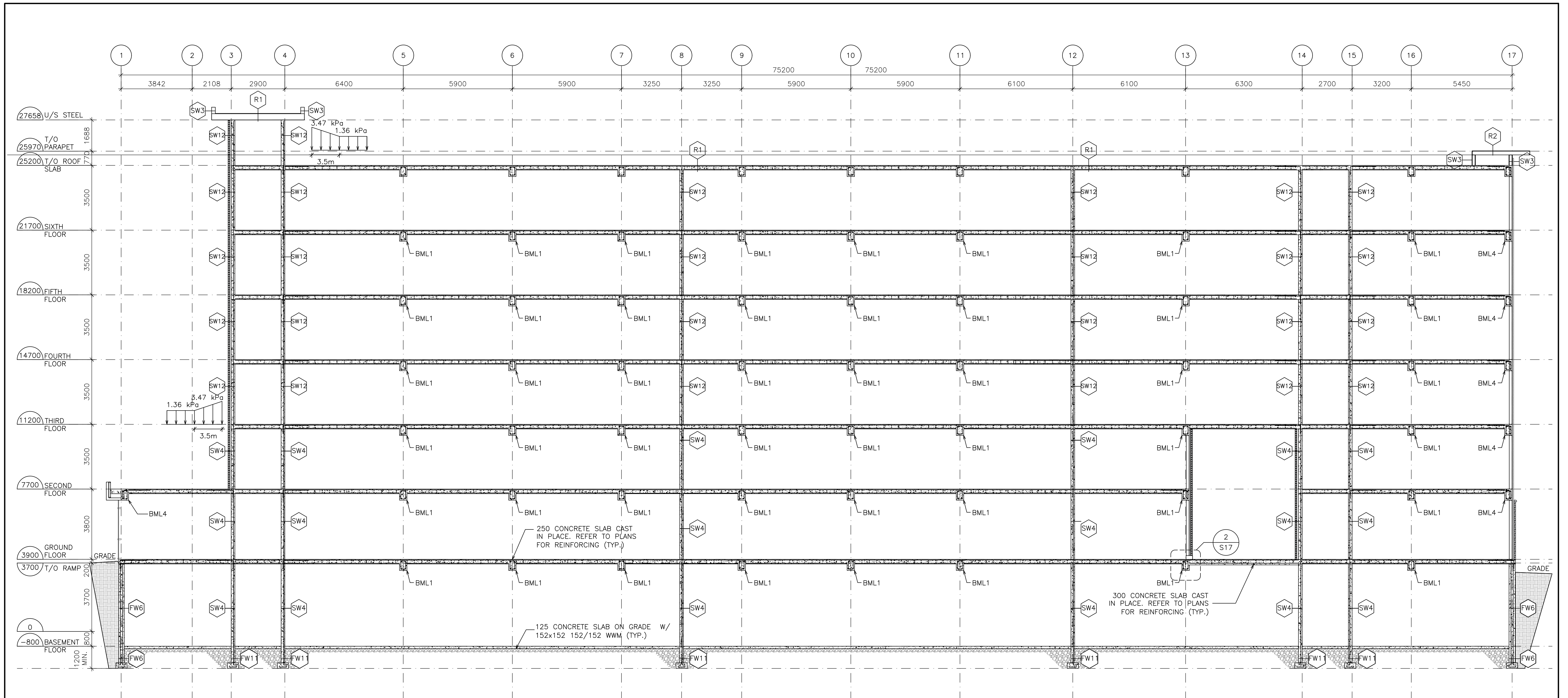

1 BUILDING SECTION  
S17 SCALE: 1:100

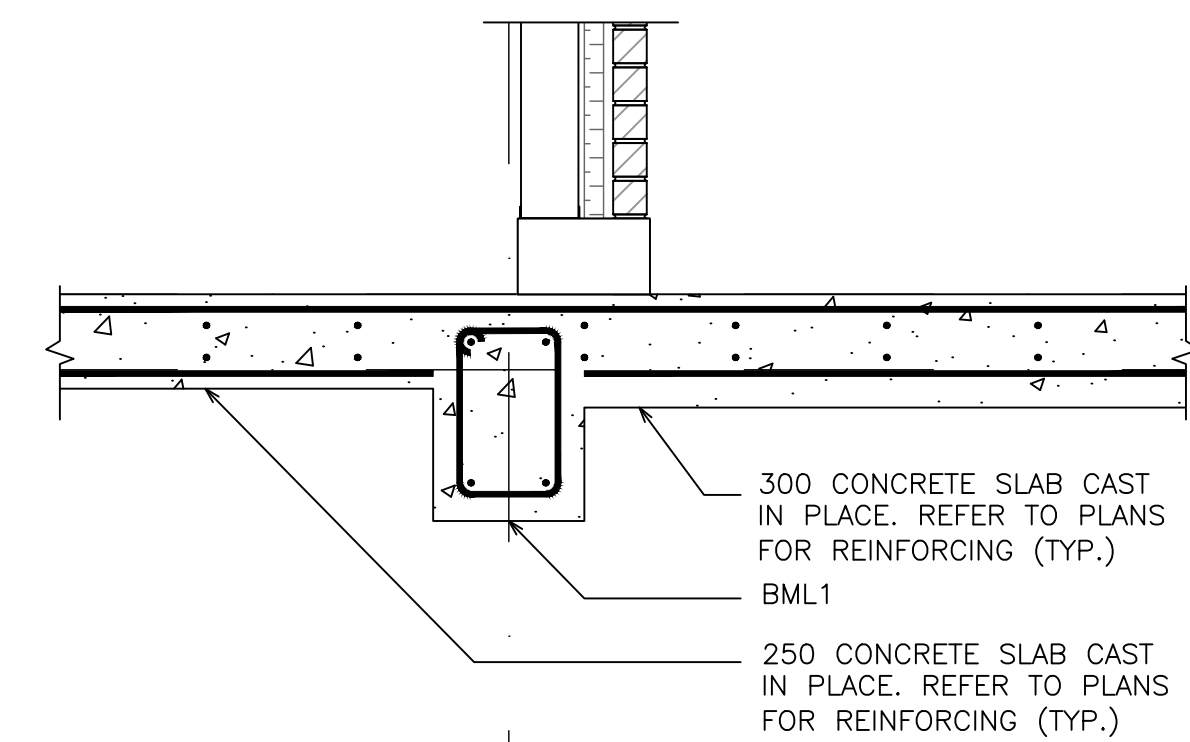

2 CONCRETE CURB DETAIL  
S17 SCALE: 1:20

1 ISSUED FOR PERMIT		20/03/30	M.S.	T.L.R.
NO.	REVISION	DATE	BY	APPROVED
REVISIONS				
513 DUNDAS STREET EAST, WHITBY, ON KIYA DEVELOPMENTS LTD.				
<b>STRUCTURAL BUILDING SECTION</b>				
<b>D.G. Biddle &amp; Associates Limited</b> consulting engineers and planners				
98 KING STREET EAST • OSHAWA, ON L1H 1B6 PHONE (905)576-8500 • FAX (905)576-9730 info@dgbiddle.com				
SCALE:	AS SHOWN	PROJECT NO.	116194	
DRAWN BY:	M.A.S.	DRAWING NO.	S17	
DESIGN BY:	T.L.R.	CAD FILE:	-	
CHECKED BY:	D.D.B.	PLOT DATE:	20/06/22	
DATE:	JANUARY 2020	SUBMISSION:	PERMIT	

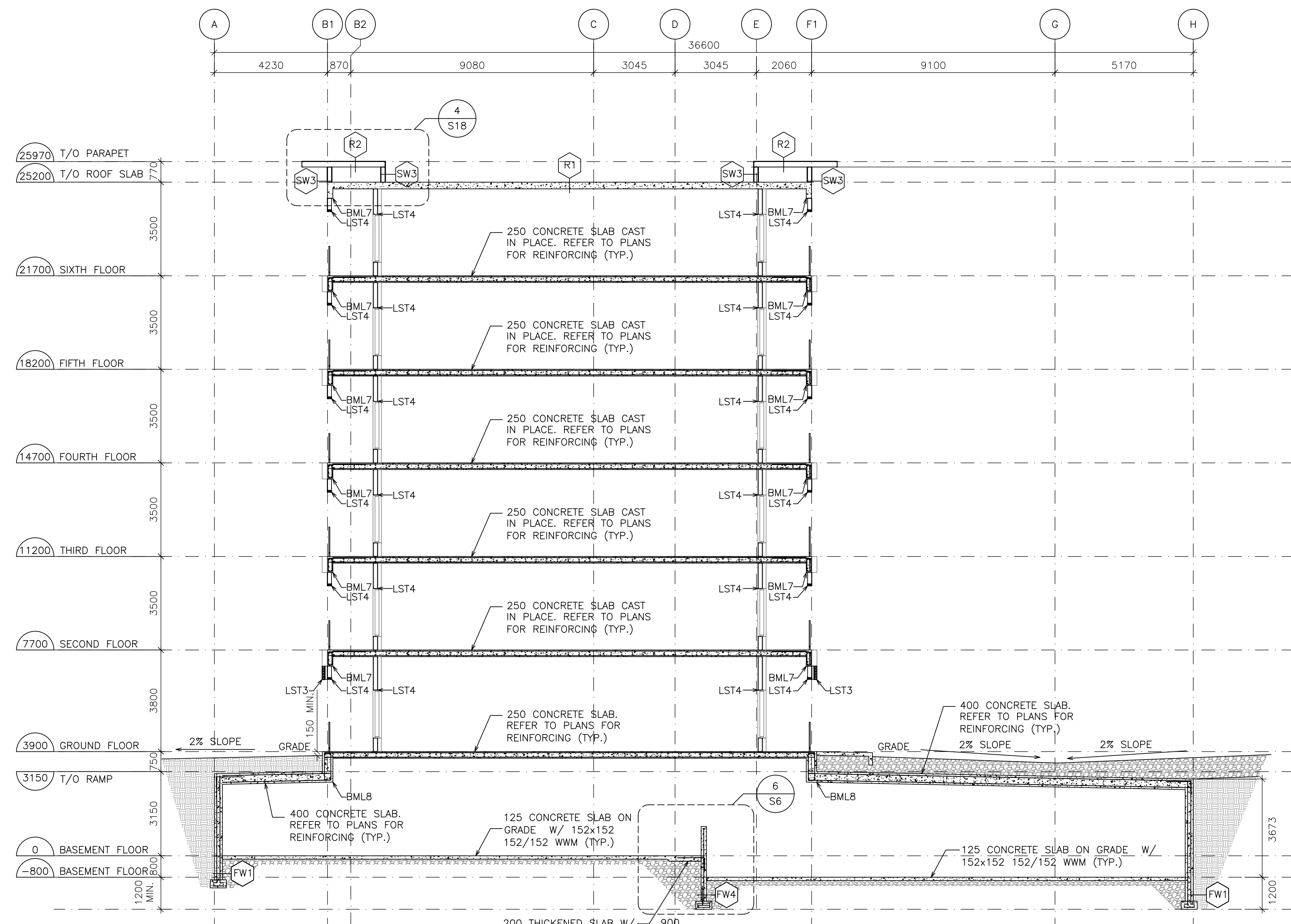

1 BUILDING SECTION  
S18 SCALE: 1:100

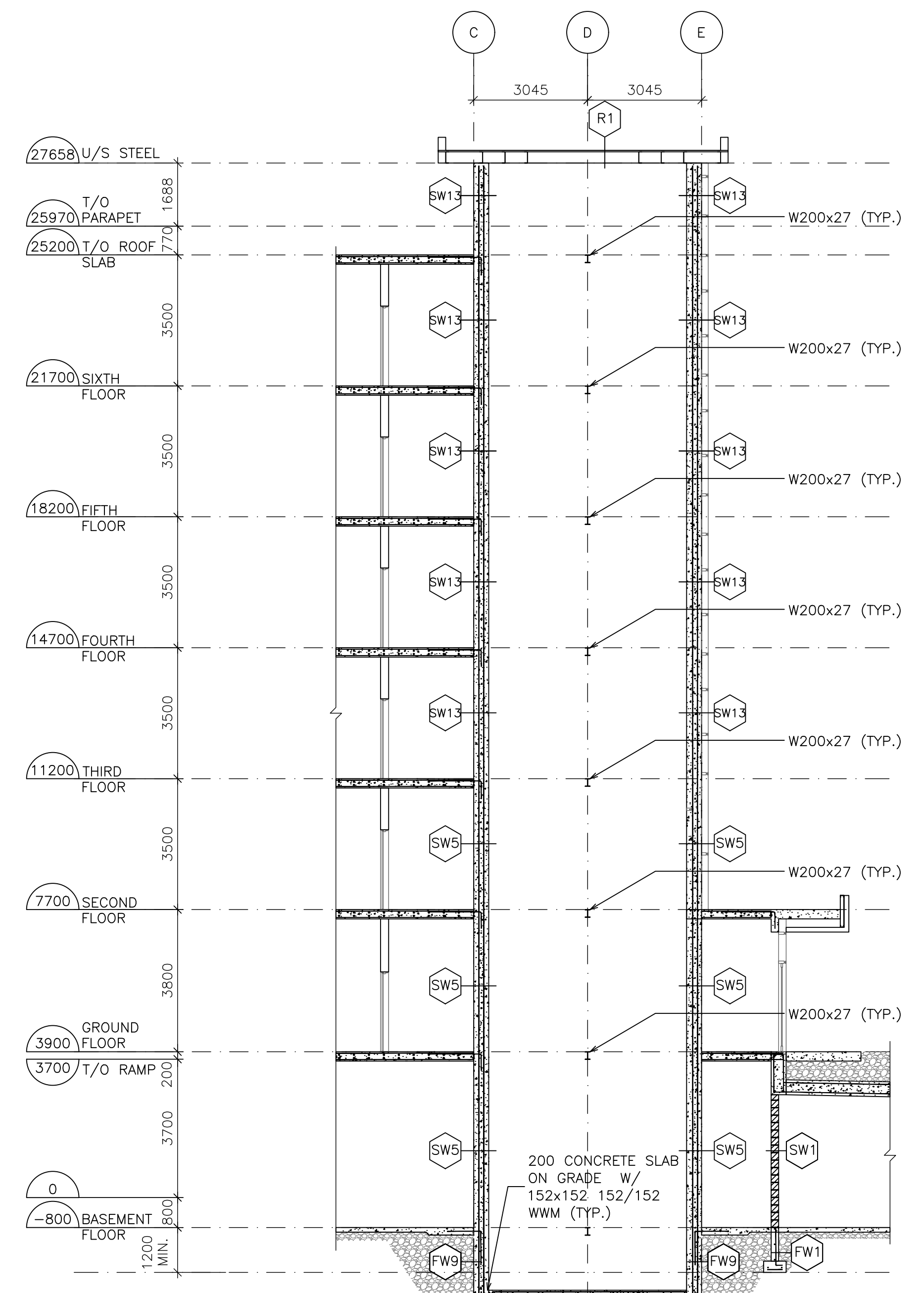

2 ELEVATOR SECTION  
S18 SCALE: 1:100

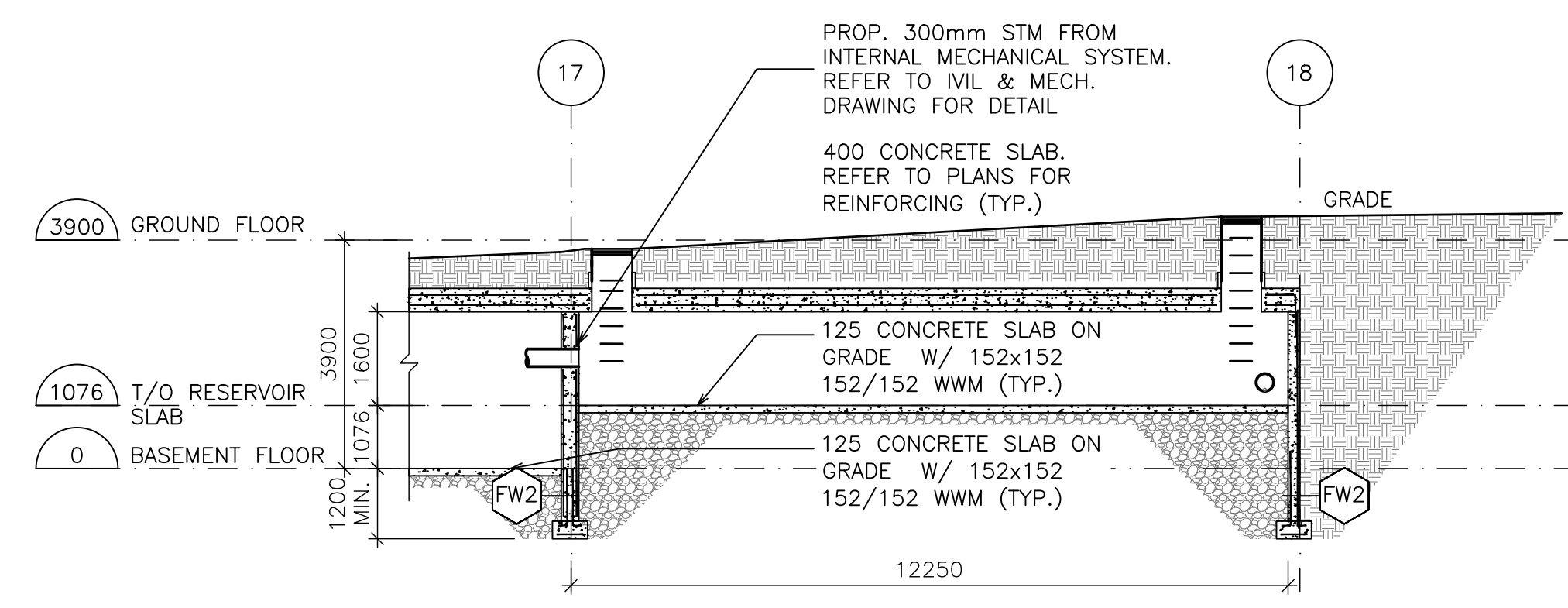

3 BUILDING SECTION  
S18 SCALE: 1:100

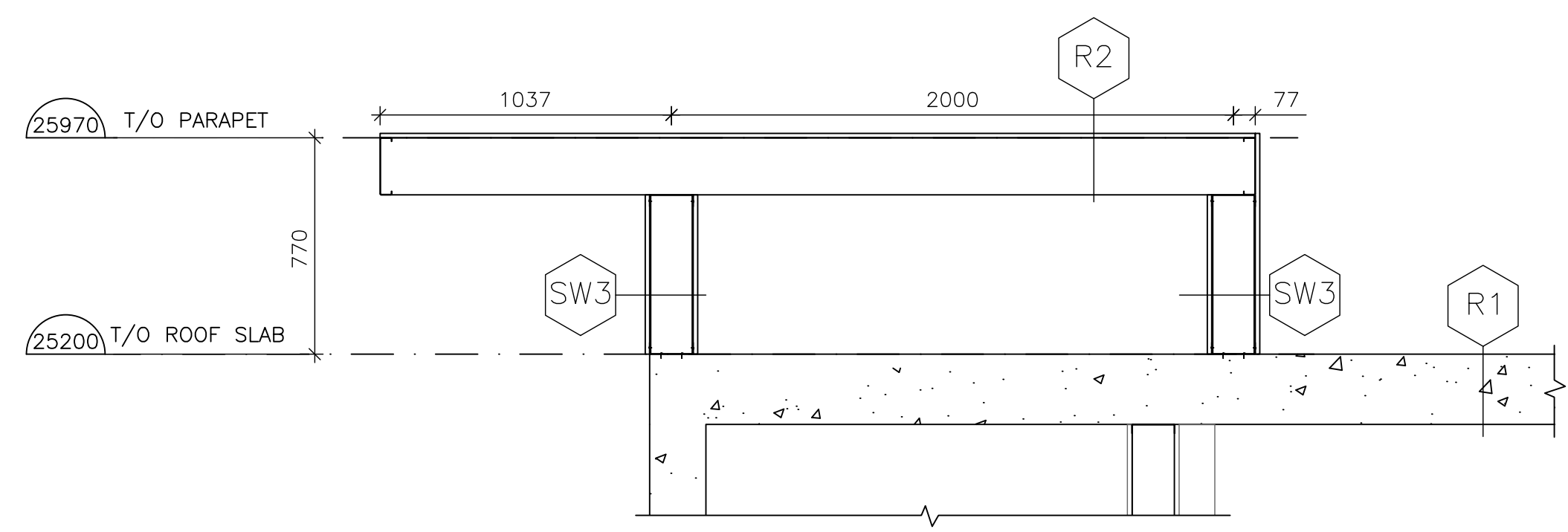

4 STRUCTURAL PARAPET DETAIL  
S18 SCALE: 1:20

1 ISSUED FOR PERMIT				20/03/30	M.S.	T.L.R.
NO.	REVISION	DATE	BY	APPROVED		
REVISIONS						
513 DUNDAS STREET EAST, WHITBY, ON KIYA DEVELOPMENTS LTD.						
<b>STRUCTURAL BUILDING SECTION &amp; DETAILS</b>						
<b>D.G. Biddle &amp; Associates Limited</b> consulting engineers and planners						
96 KING STREET EAST • OSHAWA, ON L1H 1B6 PHONE (905)576-8500 • FAX (905)576-9730 info@dgbiddle.com						
SCALE:	AS SHOWN	PROJECT NO.	116194			
DRAWN BY:	M.A.S.	DRAWING NO.	S18			
DESIGN BY:	T.L.R.	CAD FILE:	-			
CHECKED BY:	D.D.B.	PLOT DATE:	20/06/22			
DATE:	JANUARY 2020	SUBMISSION:	PERMIT			